



## INSTRUCTIONS

# Types JKW-150 to JKW-350 SUPER BUTE Current Transformers

Dry-type, Butyl-molded 150-kV through 350-kV BIL

## INTRODUCTION

These instructions apply to Types JKW-150, JKW-200, JKW-250 and JKW-350 SUPER  BUTE current transformers with standard ratings and applied under usual conditions (refer to U.S. Standards for Instrument Transformers, ANSI/IEEE C57.13). For information on unusual ratings of frequency, voltage, current, or on installations where unusual conditions exist, consult the nearest sales office of the General Electric Company. When special information is requested, give the complete nameplate data to identify the transformer.

These transformers are of dry-type, butyl-molded construction. The nominal system voltages for the four types are 25, 34.5, 46, and 69 kV, respectively.

**NOTE:** In addition to this instruction book, further general information on dry-type instrument transformers can be found in Instructions GEH-230.

## BEFORE INSTALLATION

### INSPECTION

Immediately upon receiving the transformer, inspect it for physical damage that may have occurred during shipment or handling. If damage is evident, file a claim with the transportation company immediately and promptly notify the nearest General Electric Company sales office.

These butyl-molded current transformers are practically impervious to moisture. If, due to unusual circumstances, insulation tests indicate the possibility of the entrance of moisture, refer to the nearest GE Sales Office for detailed information on proper procedure.

Make sure that the short-circuit jumper is securely in place on at least two terminals of each secondary provided. Do not remove or cut away a jumper until the secondary circuit in question is closed through a suitable burden.

### TESTING

Insulation tests should be made in accordance with ANSI/IEEE Standard C57.13.

**NOTE:** Periodic field tests of insulation should not exceed 65 percent of factory test voltage.

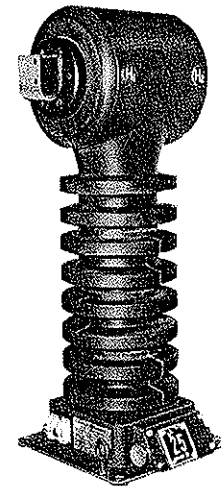

Fig. 1. Type JKW-200 CT, 200-kV BIL

For ratio and phase-angle tests, refer to the Handbook for Electricity metering, ANSI/IEEE Standard C57.13, and General Electric publications GET-97 and GET-1725.

## INSTALLATION

### SAFETY PRECAUTIONS

1. Always consider an instrument transformer as a part of the circuit to which it is connected, and do not touch the leads and terminals or other parts of the transformer unless they are known to be adequately grounded.

2. The insulation surface of molded transformers should be considered the same as the surface of a porcelain bushing, since a voltage stress exists across the entire insulation surface from terminals to grounded metal parts.

3. Always ground the metallic cases, frames, bases, etc., of instrument transformers. The secondaries should be grounded close to the transformers. However, when secondaries of transformers are interconnected, there should be only one grounded point in this circuit to prevent accidental paralleling with system grounding wires.

4. Do not open the secondary circuit of a current transformer while the transformer is energized, and do not energize while the secondary circuit is open. Current transformers may develop open-circuit secondary voltages which may be hazardous to personnel or damaging to the transformer or equipment connected in the secondary circuit.

### HANDLING

These butyl-molded transformers, although far less fragile than porcelain-insulated transformers, should nevertheless be handled with reasonable care. It is recommended that, wherever possible, the transformer be left attached to its shipping pallet and moved in this manner up to the actual installation site. If the transformer is unbolted from the pallet, it should be considered as unstable, and therefore should be adequately supported. The transformer can be lifted with a sling attached to lifting eyebolts in the base. The top end of the transformer should be securely attached to the sling. See Fig. 2 for vertical and horizontal lifting.

### MOUNTING

These current transformers can be mounted in any position from upright to inverted, providing the centerline through the

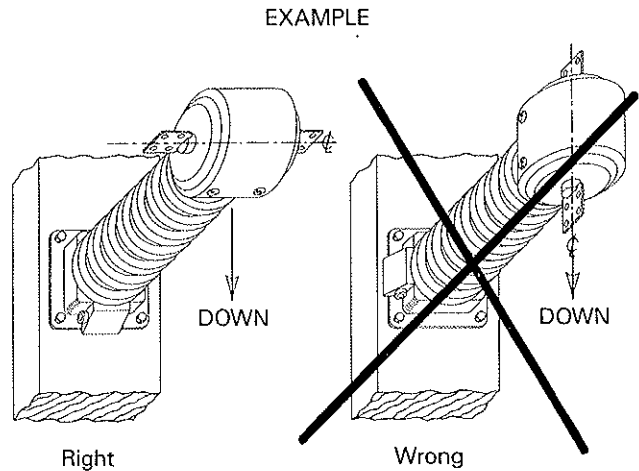

Fig. 3. Examples of right and wrong CT mounting

primary terminals is horizontal. Figure 3 illustrates right and wrong ways for mounting.

Loading by lines or busswork should be kept to a minimum to avoid placing appreciable strain upon the transformer bushings and terminals. The maximum recommended loading from all sources should not be greater than the equivalent of a 200-pound external force applied at the axis of the primary terminals.

### CONNECTIONS

The resistance of all connections should be kept at a minimum to prevent overheating of the terminals and to prevent an increase in the secondary burden. The resistance of the secondary leads should be included in calculating the impedance of the burden on the transformer. The total burden should be kept within the limits of the CT rating.

The standard Type JKW current transformers use a tapped secondary winding for obtaining a dual-primary current rating. For standard designs, secondary connections are to be made as follows: For the lower primary current rating, connect the secondary burden to terminals X<sub>2</sub> and X<sub>3</sub>. Leave terminal X<sub>1</sub> "open" (no connection). For the higher primary current rating, connect the secondary burden to terminals X<sub>1</sub> and X<sub>3</sub>. Leave terminal X<sub>2</sub> "open" (no connection).

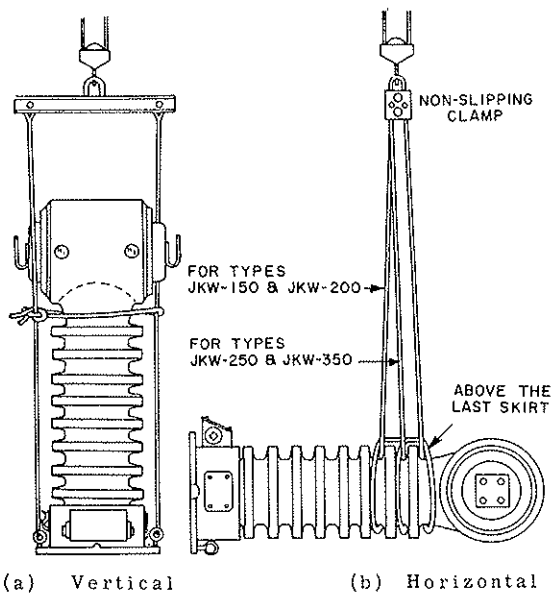

Fig. 2. Method of lifting transformers

*These instructions do not purport to cover all details or variations in equipment nor to provide for every possible contingency to be met in connection with installation, operation or maintenance. The equipment covered by these operating instructions should be operated and serviced only by competent technicians familiar with good safety practices, and these instructions are written for such personnel and are not intended as a substitute for adequate training and experience in safe procedures for this type of equipment. Should further information be desired or should particular problems arise which are not covered sufficiently for the purchaser's purposes, the matter should be referred to the General Electric Company.*

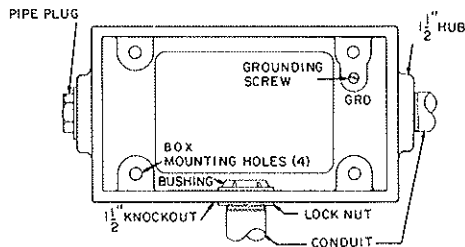

Fig. 4. Conduit box connections

A detachable conduit box (Fig. 4) is provided for housing the secondary terminals. Two 1 1/2-in. threaded horizontal hubs with pipe plugs are provided for making connection to 1 1/2-in. conduit. A knockout is also provided on the bottom of the box for use in locations requiring bottom connection. A lock nut and bushing will secure the conduit to the box, as shown in Fig. 4. A reducing bushing will be required if a smaller diameter conduit is used. The transformer may be taken out of service without dismantling the conduit merely by disconnecting the secondary leads and removing the four conduit-box mounting screws.

### PRIMARY BY-PASS PROTECTION

The primaries of these current transformers having wound-type construction are provided with by-pass protection. External by-pass protectors may be used, but are not necessary.

### GROUNDING

A good, permanent, low-impedance ground is essential for adequate protection. The conduit box (Fig. 4) contains a provision for grounding the secondary to the transformer base. Also a ground connector, designed to accept ground wires in the range of No. 2 solid through 500-MCM cable, is provided on the transformer base.

### POLARITY

When wiring instrument transformer circuits, it is necessary to maintain the correct polarity relationship between the line and the devices connected to the secondaries. The relative instantaneous polarity of each winding is indicated by a marker near each primary and secondary terminal. Where taps are present, all terminals are marked in order. The primary terminals are  $H_1$  and  $H_2$ ; the secondary terminals are  $X_1$ ,  $X_2$ ,  $X_3$ , etc; also  $Y_1$ ,  $Y_2$ ,  $Y_3$ , etc., if another secondary is provided.  $H_1$  always indicates the same instantaneous polarity as  $X_1$  and  $Y_1$ . Instantaneous current flow may be visualized as into  $H_1$  and out of  $X_1$  and  $Y_1$  in the full winding connection (out of  $X_2$  and  $Y_2$  on the tap connection).

### AMBIENT TEMPERATURE

These transformers are designed to operate over the ambient temperature range as indicated at the standard ratings (see nameplate), provided the altitude does not exceed 3300 feet.

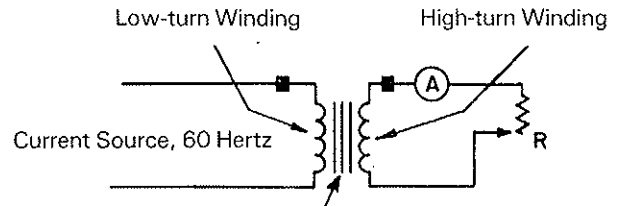

Current Transformer to be Demagnetized

**NOTE:** The high-turn winding of a CT is the winding with the lower rated current.

Fig. 5. Circuit for demagnetizing current transformers

If the transformers are to be used above 3300 feet, consult ANSI/IEEE Standard C57.13 for the effect of the altitude on temperature rise.

## MAINTENANCE

Whether mounted indoors or outdoors, these current transformers require no special care other than keeping the insulation surfaces free from accumulations of dirt.

### CLEANING

Butyl-molded transformers may be cleaned by scrubbing the butyl surface with detergent and a stiff brush to remove accumulated dirt. Remove the detergent by washing with clean water. Application of a light grade of silicone oil to the butyl surface may help to renew surface appearance.

### DEMAGNETIZING

If a current transformer becomes magnetized, it should be demagnetized before being used for precision work. ANSI/IEEE C57.13 lists methods for demagnetizing current transformers.

One method is to connect the transformer in the test circuit as shown in Fig. 5. Pass rated current through the low-turn winding (usually the primary). Increase the resistance ( $R$ ) in the high-turn winding (usually the secondary) circuit until the transformer core is saturated; then, slowly reduce resistance to zero and disconnect the current source. Saturation of the core is indicated by a reduction of current in the high-turn winding circuit.

On tapped-secondary current transformers, demagnetizing should be done using the  $X_2$ – $X_3$  section of the winding to reduce the voltage required for saturation.

On dual-secondary current transformers, the two secondaries should be paralleled during demagnetizing.

**WARNING:** A CONTINUOUSLY VARIABLE RESISTANCE MUST BE USED TO AVOID OPENING THE HIGH-TURN WINDING CIRCUIT WHEN RESISTANCE VALUES ARE CHANGED. AS THE RESISTANCE IS INCREASED, THE VOLTAGE ACROSS THE RESISTANCE WILL APPROACH OPEN-CIRCUIT VALUE.

# GEI-52426, Types JKW-150 to JKW-350 Current Transformers

## DIMENSIONS

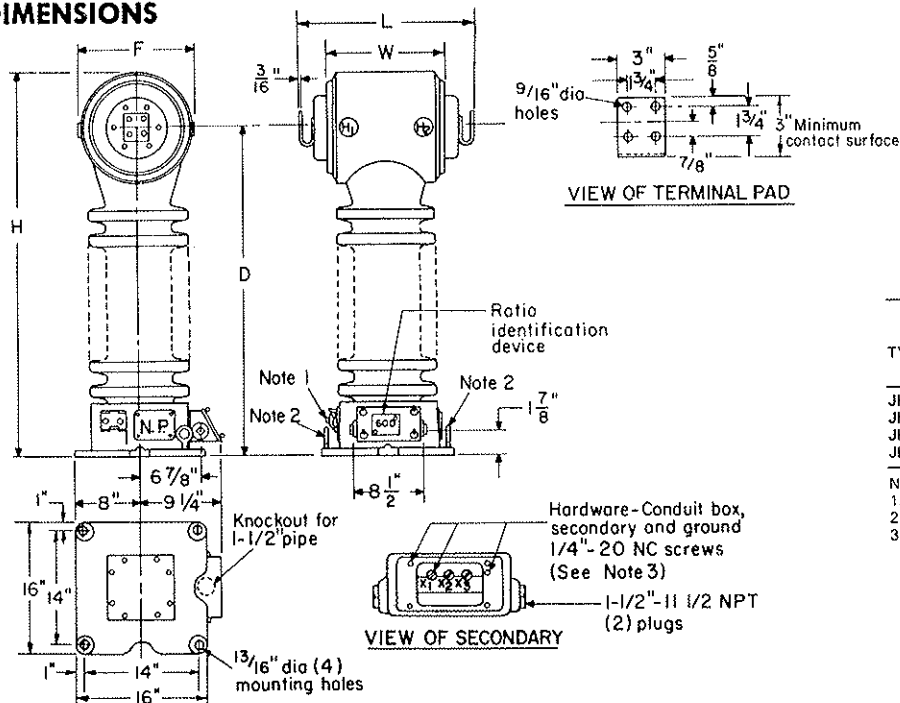

TYPE	DIMENSIONS IN INCHES				
	D	F	H	L	W
JKW-150	32 1/8	13 7/16	38 1/2	21	14 3/4
JKW-200	38 1/8	13 7/16	44 1/2	21	14 3/4
JKW-250	44 1/8	17 1/2	52 1/2	23 1/16	16 3/4
JKW-350	51 1/8	17 1/2	59 1/2	23 1/16	16 3/4

### NOTES:

1. Ground clamp for No. 2 solid to 500 MCM cable.
  2. Lifting bolts (2) 1-3/8" dia hole (for vertical lift only).
  3. Single-secondary CT's - for the lower primary current rating, connect the secondary burden to terminals X<sub>2</sub> and X<sub>3</sub>. Leave terminal X<sub>1</sub> "open" (no connection). For the higher primary current rating, connect the secondary burden to terminals X<sub>1</sub> and X<sub>3</sub>. Leave terminal X<sub>2</sub> "open" (no connection).
- Double-secondary CT's - if secondaries X and Y are both used, connect each secondary the same as a single-secondary CT. If one secondary is not used, short-circuit all of its terminals (X<sub>1</sub>-X<sub>2</sub>-X<sub>3</sub> or Y<sub>1</sub>-Y<sub>2</sub>-Y<sub>3</sub>).

Fig. 6. Outline Dimensions, Types JKW-150 through JKW-350; 25/50: 5- through 300/600: 5-ampere ratings

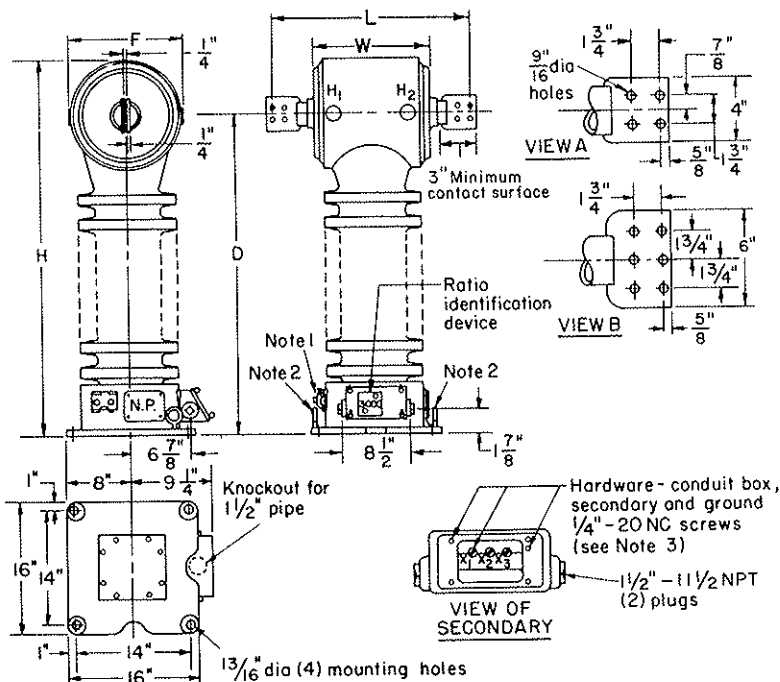

Primary Amp Rating	Pad View	No. of Pads
400/800	A	1
500/1000	A	1
600/1200	A	1
800/1600	A	2
1000/2000	A	2
1500/3000	B	3

TYPE	DIMENSIONS IN INCHES				
	D	F	H	L	W
JKW-150	31 3/4	13 7/16	38 1/2	23 3/4	14 3/4
JKW-200	37 3/4	13 7/16	44 1/2	23 3/4	14 3/4
JKW-250	43 3/4	17 1/2	52 1/2	25 3/4	16 3/4
JKW-350	50 3/4	17 1/2	59 1/2	25 3/4	16 3/4

### NOTES:

1. Ground clamp for No. 2 solid to 500 MCM cable.
  2. Lifting bolts (2) 1-3/8" dia hole (for vertical lift only).
  3. Single-secondary CT's - for the lower primary current rating, connect the secondary burden to terminals X<sub>2</sub> and X<sub>3</sub>. Leave terminal X<sub>1</sub> "open" (no connection). For the higher primary current rating, connect the secondary burden to terminals X<sub>1</sub> and X<sub>3</sub>. Leave terminal X<sub>2</sub> "open" (no connection).
- Double-secondary CT's - if X and Y are both used, connect each secondary the same as a single-secondary CT. If one secondary is not used, short-circuit all of its terminals (X<sub>1</sub>-X<sub>2</sub>-X<sub>3</sub> or Y<sub>1</sub>-Y<sub>2</sub>-Y<sub>3</sub>).

Fig. 7. Outline dimensions, Types JKW-150 through JKW-350; 400/800:5- through 1500/3000:5-ampere ratings