

Multilin™ B90

LOW IMPEDANCE BUS DIFFERENTIAL SYSTEM

Secure, dependable and scalable bus differential protection system for LV, HV and EHV busbars



KEY BENEFITS

- High speed protection algorithm for enhanced stability with trip times of 0.75 power cycle
- Superior CT saturation detector capable of detecting CT saturation even with only 2 msec of saturation free current for enhanced through fault stability
- Ambient temperature monitoring with alarming when outside temperature exceeds upper thresholds
- Suitable for different bus configurations, scalable architecture to protect up to 24 feeders.
- Pre Engineered Bus protection system - Use experienced GE Energy application engineers to develop busbar protection system for your specific configurations
- Use high speed communications to reduce wiring and installation costs - Exchange inputs and outputs between relays to achieve relay-to-relay interaction
- Robust network security enabling Critical Infrastructure Protection through user command logging, and dual permission access control
- Integrated isolator position monitoring & alarming

APPLICATIONS

- Re-configurable multi-section busbar with up to 24 feeders
- Single Bus, Breaker and half bus bar configurations, Double Bus and Triple Bus with and without bus couplers

FEATURES

Protection and Control

- Multi-zone bus differential protection with restrained and unrestrained function
- Fast and reliable CT saturation detection
- Breaker failure protection
- End fault (dead zone) protection
- Check-zone functionality
- CT ratio mismatch compensation
- Dynamic Bus Replica
- Back-up time and instantaneous overcurrent elements
- Undervoltage function for supervision purposes

Communications

- Networking options - Ethernet-fiber (optional redundancy), RS422, RS485, G.703, C37.94
- Multiple protocols - IEC 61850, DNP 3.0 Level 2, Modbus RTU, Modbus TCP/IP, IEC 60870-5-104
- Direct I/O - secure, high-speed exchange of data between URs

Monitoring and Metering

- Isolator monitoring (up to 48) and alarming
- CT trouble monitoring
- VT supervision
- Metering - current, voltage, frequency
- Oscillography - 64 samples/cycle, up to 64 records
- Event Recorder - 1024 time tagged events, with 0.5 ms scan of digital inputs

EnerVista™ Software

- State of the art software for configuration and commissioning Multilin products
- Graphical Logic Designer and Logic Monitor to simplify designing and testing procedures
- Document and software archiving toolset to ensure reference material and device utilities are up-to-date
- EnerVista™ Integrator providing easy integration of data in the B90 into new or existing monitoring and control systems

Protection and Control

The B90 Bus Differential System provides fast and secure low impedance bus protection for reconfigurable LV, HV, and EHV busbars. Use one B90 to protect up to 8 feeders and use three or more B90s together in a centralized phase segregated architecture to protect up to 24 feeders. Many busbar applications such as single, double, triple, breaker-and-a-half with or without transfer bus can be protected using the B90. The B90 is ideally suited in applications where high impedance schemes were typically used. Part of the Universal Relay family, the B90 comes with a variety of versatile features truly integrating protection, monitoring, metering, communication and control in one easy-to-use device. The Universal Relay family offers higher degree of modularity in its design and functionality providing superior performance in protection and control meeting the toughest requirements of the marketplace.

Segregated Bus Differential Protection

The B90 provides fast and secure low impedance bus protection with sub-cycle tripping times averaging 0.75 cycles. Multiple phase-segregated zones of differential protection are available in the B90. The primary protection is based on differential and directional protection principles, and uses a dedicated CT saturation mechanism for additional

B90 - Protection, Metering, Monitoring and Control

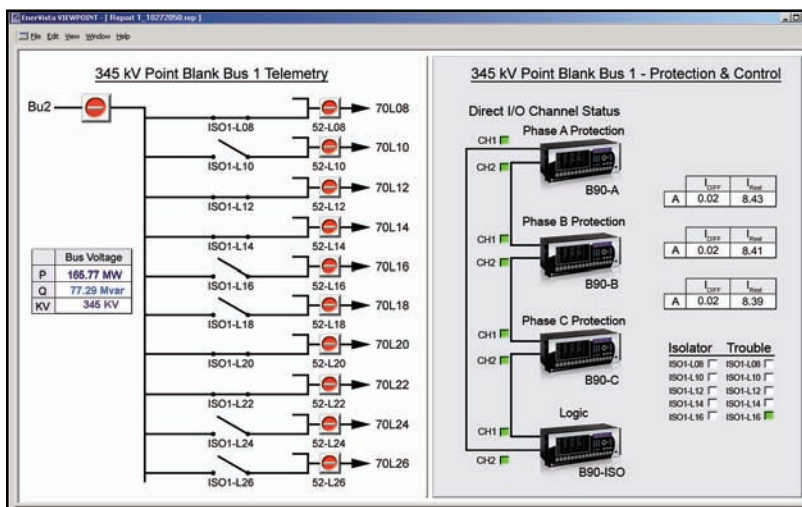

The B90 is the single point for protection, control, metering, and monitoring in one integrated device that can easily be connected directly into DCS or SCADA monitoring and control systems like Viewpoint Monitoring as shown.

through-fault stability. This mechanism is capable of detecting saturation of CTs as quickly as two milliseconds into an external fault. The overall system costs can be reduced with the B90 since there is no need for dedicated or interposing, external CTs. It's extreme flexibility, which includes a CT ratio mismatch of up to 32:1 between feeders, makes the B90 an ideal solution in a wide variety of bus differential applications.

Architecture

The B90 is based on a centralized phase-segregated architecture that does not rely

on extensive communications between IEDs, an approach that increases overall reliability. This architecture allowing for greater flexibility and is scalable to any low impedance busbar protection application, all in a relatively small form factor. Each unit in the system is capable of exchanging digital states quickly and reliably over Direct I/O, allowing the user to distribute input and output contacts in various IEDs. The B90 protection system can incorporate as few as one IED and as many as five IEDs to accommodate a wide range of applications. This scalability and flexibility allows for optimum hardware utilization with an overall lower system

Functional Block Diagram

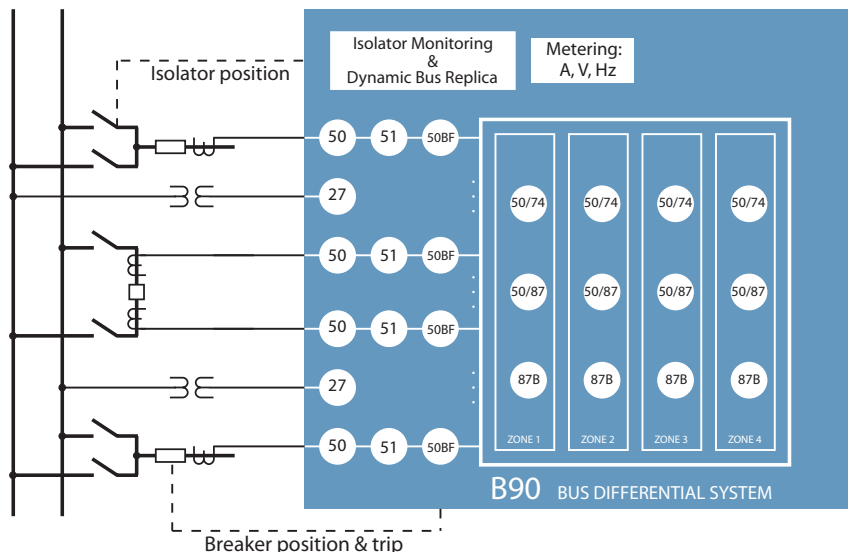

ANSI Device Numbers & Functions

Device Number	Function
27	Undervoltage
50	Instantaneous Overcurrent
50/74	CT Trouble
87B	Bus Differential
51	Time Overcurrent
50BF	Breaker Fail

costs then was not previously possible. A single B90 configuration is available to protect up to 8 feeders. A more typical B90 configuration for non-re-configurable busbars without breaker fail protection consists of three B90s. This configuration can protect up to 24 feeders. Each B90 in the system can also be configured to support multiple I/O configurations (up to 48 inputs or up to 18 outputs on each unit). If breaker failure, isolator monitoring functions, and more I/O points are needed, an additional B90 can be added into the system. A fifth unit can also be added for even more I/O capabilities.

Dynamic Bus Replica

The B90 provides a dynamic bus replica for each zone of differential protection. Built-in programmable logic removes the need for external auxiliary relays, and provides the ability to include or exclude currents dynamically from the differential zone. This allows the B90 to follow the actual busbar configuration with no external switching of CT circuits required. The B90 also avoids blind and overtripping spots in simple bus configurations. Reliability is increased and costs reduced by eliminating auxiliary

relays that would otherwise be used for switching physical currents. The ability to monitor auxiliary switches and a contact discrepancy alarm also provides increased security.

Breaker Failure Protection

Three-pole breaker failure (BF) protection is available. The B90 system provides for up to 24 BF elements that can respond to currents and/or auxiliary contacts. The current supervision provides fast reset time and separate settings for low-set and hi-set supervision in the phase IEDs. The BF can be initiated internally from the busbar protection or externally via input contacts or communications.

Overcurrent Protection

Backup protection is available with instantaneous and time overcurrent functions for each current input of the B90 system. For supervision purposes, an undervoltage function is also provided for each voltage input of the B90 system.

- Time O/C elements can individually be set to use IEEE, IEC or custom FlexCurves™

End Fault (Blind Spot) Protection

The location of the current transformer normally limits the zone of the busbar protection and can create a blind spot when the isolator is open. The section between the current transformer and the circuit breaker can be effectively protected by means of the end-fault protection. In the event of a fault, instantaneous and selective tripping of the busbar section or inter tripping of the circuit-breaker at the remote end can be configured.

Check-Zone

The B90 provides for multiple zones of differential protection. One zone can be configured to encompass the entire busbar in order to act as a supervisory check zone for other zones of protection.

CT Trouble Monitoring

One CT trouble monitoring function is provided for each zone of differential protection. The element is a definite time TOC function responding to a differential current. The CT trouble element shall be used in conjunction with undervoltage supervision or a check zone.

Typical B90 Configurations

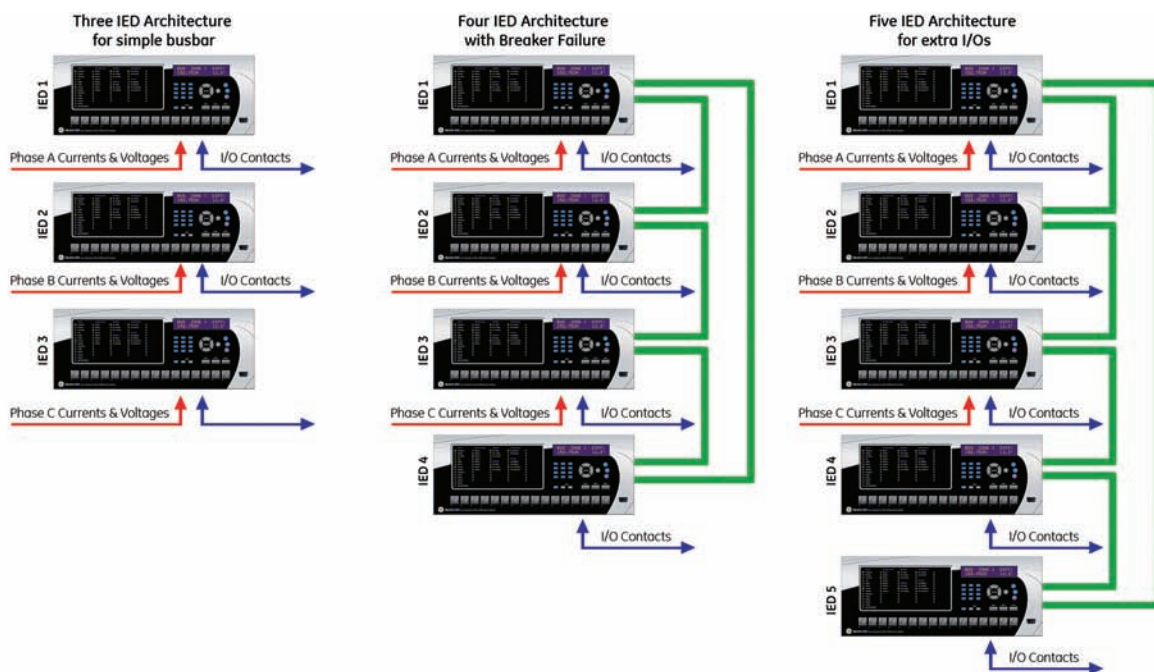

Advanced Automation

The B90 incorporates advanced automation features including powerful FlexLogic™ programmable logic, communication, and SCADA capabilities that far surpass what is found in the average bus protection relay. The B90 integrates seamlessly with other UR relays for complete system protection

FlexLogic™

FlexLogic™ is the powerful UR-platform programming logic engine that provides the ability of creating customized protection and control schemes thereby minimizing the need, and the associated costs, of auxiliary components and wiring. Using FlexLogic™, the B90 can be programmed to provide required tripping logic along with custom scheme logic.

Scalable Hardware

The B90 is available with a multitude of I/O configurations to suit the most demanding

application needs. The expandable modular design allows for easy configuration and future upgrades.

- Multiple CT/VT configurations allow for implementation of many different schemes
- Flexible, modular I/O covering a broad range of input signals and tripping schemes
- Types of digital outputs include trip-rated Form-A and Solid State Relay (SSR) mechanically latching, and Form-C outputs
- Form-A and SSR outputs available with optional circuit continuity monitoring and current detection to verify continuity and health of the associated circuitry
- Mechanically latching outputs can be used to develop secure interlocking applications and replace electromechanical lockout relays

Monitoring and Metering

The B90 includes high accuracy metering and recording for all AC signals. Voltage, current, and power metering are built into the relay as a standard feature. Current and voltage parameters are available as total RMS magnitude, and as fundamental frequency magnitude and angle.

Fault and Disturbance Recording

The advanced disturbance and event recording features within the B90 can significantly reduce the time needed for postmortem analysis of power system events and creation of regulatory reports. Recording functions include:

- Sequence of Event (SOE)
 - 1024 time stamped events
- Oscillography,
 - 64 digital & up to 40 Analog channels

Built-in Advanced Disturbance Recording

The built-in advanced disturbance recording function allows users to view the COMTRADE files and trouble shoot bus fault. The internal operation of the B90 elements, logic, and outputs can be monitored in real time to simplify commissioning and troubleshooting procedures. Two cases are shown here:

External Fault:

Even with heavy CT saturation and with only 1 msec of saturation free current B90 is stable for through faults. See the Directional Comparison element output, which adds additional security to the bus differential function

Internal Fault:

For internal fault the CT saturation flag is not set and the directional element output is safely ignored resulting in an operating time of less than 10 msec.

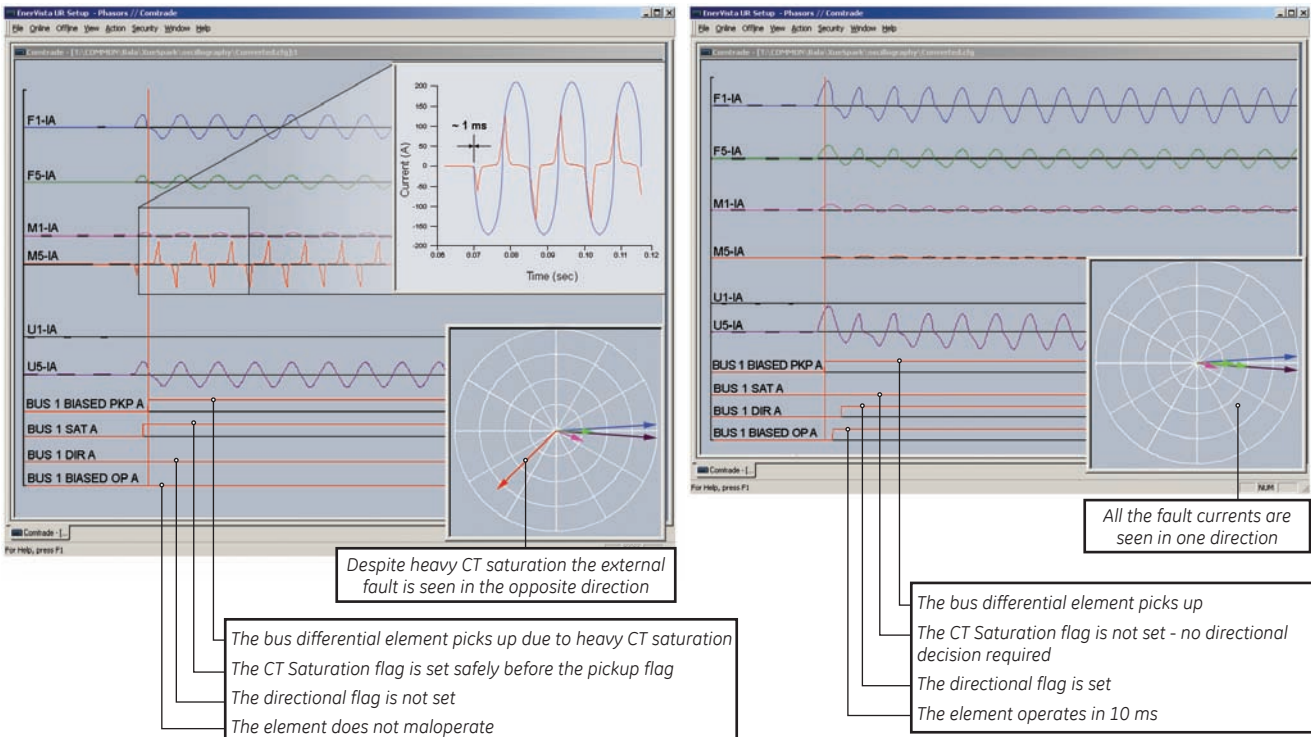

- Data Logger, disturbance recording
 - 16 channels up to 1 sample / cycle / channel
- Fault Reports
 - Powerful summary report of pre-fault and fault values

The very high sampling rate and large amount of storage space available for data recording in the B90 can eliminate the need for installing costly standalone recording equipment.

Advanced Device Health Diagnostics

The B90 performs comprehensive device health diagnostic tests during startup and continuously at runtime to test its own major functions and critical hardware. These diagnostic tests monitor for conditions that could impact security and availability of protection, and present device status via SCADA communications and front panel display. Providing continuous monitoring and early detection of possible issues helps improve system uptime.

- Comprehensive device health diagnostic performed during startup
- Monitors the CT/VT input circuitry to validate the integrity of all signals

Communications

The B90 provides for secure remote data and engineering access, making it easy and flexible to use and integrate into new and existing infrastructures. Fiber optic Ethernet provides high-bandwidth communications allowing for low-latency controls and high-speed file transfers of relay fault and event record information. The available redundant Ethernet option provides the means of creating fault tolerant communication architectures in an easy, cost-effective manner.

The B90 supports the most popular industry standard protocols enabling easy, direct integration into DCS and SCADA systems.

- IEC 61850
- DNP 3.0
- IEC 60870-5-104
- Modbus RTU, Modbus TCP/IP

User Programmable Logics for Custom Schemes

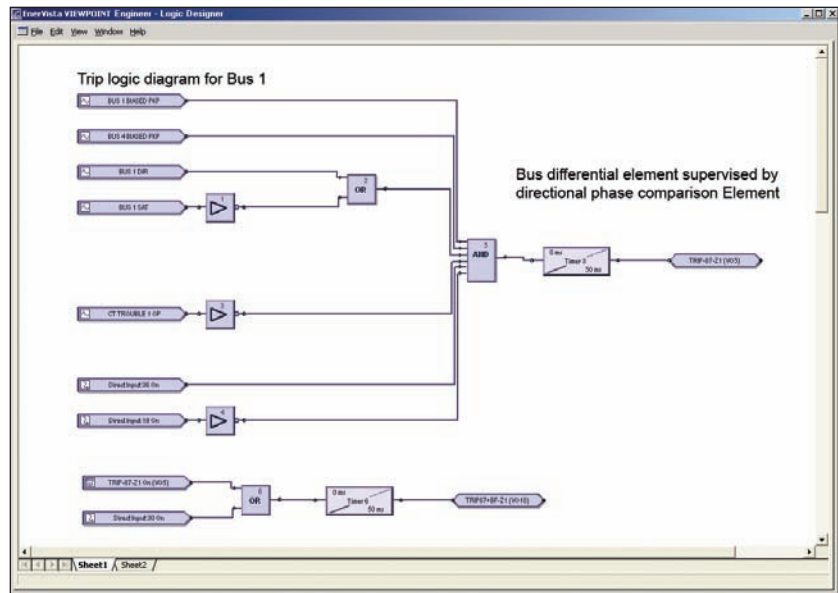

Flexlogic allows for customizing the B90 outputs for most bus protection schemes and applications

Interoperability with Embedded IEC 61850

The B90 with integrated IEC 61850 can be used to lower costs associated with bus protection, control and automation. GE Energy's leadership in IEC 61850 comes from thousands of installed devices and follows on GE Energy's extensive development experience with UCA 2.0.

- Replace expensive copper wiring between devices with direct transfer of data using GOOSE messaging
- Configure systems based on IEC 61850 and also monitor and troubleshoot them in real-time with EnerVista Viewpoint Engineer
- Integrate Multilin IEDs and generic IEC 61850-compliant devices seamlessly in EnerVista Viewpoint Monitoring

Direct I/O Messaging

Direct I/O allows for sharing of high-speed digital information between multiple UR relays via direct back-to-back connections or multiplexed through a standard DS0 multiplexer channel bank. Regardless of the connection method, Direct I/O provides continuous real-time channel monitoring that supplies diagnostics information on channel health.

Direct I/O provides superior relay-to-relay communications that can be used in advanced interlocking, and other special protection schemes.

- Communication with up to 16 UR relays in single or redundant rings rather than strictly limited to simplistic point-to-point configurations between two devices
- Connect to standard DS0 channel banks through standard RS422, G.703 or IEEE C37.94 interfaces or via direct fiber optic connections
- No external or handheld tester required to provide channel diagnostic information

Multi-Language

The B90 supports English, French, Russian, Chinese and Turkish Languages on the front panel, EnerVista setup software, and product manual. Easily switch between English and an additional language on the local displays without uploading new firmware.

EnerVista™ Software

The EnerVista™ Suite is an industry-leading set of software programs that simplifies every aspect of using the B90 relay. The EnerVista suite provides all the tools to monitor the status of the protected asset, maintain the relay, and integrate information measured by the B90 into DCS or SCADA monitoring systems. Convenient COMTRADE and Sequence of Events viewers are an integral part of the UR Setup software included with every UR relay, to carry out postmortem event analysis to ensure proper protection system operation.

EnerVista™ Launchpad

EnerVista™ Launchpad is a powerful software package that provides users with all of the setup and support tools needed for configuring and maintaining Multilin products. The setup software within Launchpad allows configuring devices in real-time by communicating using serial, Ethernet, or modem connections, or offline by creating setting files to be sent to devices at a later time. Included in Launchpad is a document

archiving and management system that ensures critical documentation is up-to-date and available when needed. Documents made available include:

- Manuals
- Application Notes
- Guideform Specifications
- Brochures
- Wiring Diagrams
- FAQs
- Service Bulletins

Viewpoint Engineer

Viewpoint Engineer is a set of powerful tools that will allow the configuration and testing of UR relays at a system level in an easy-to-use graphical drag-and-drop environment. Viewpoint Engineer provides the following configuration and commissioning utilities:

- Graphical Logic Designer
- Graphical System Designer
- Graphical Logic Monitor
- Graphical System Monitor

EnerVista™ Integrator

EnerVista™ Integrator is a toolkit that allows seamless integration of Multilin devices into new or existing automation systems. Included in EnerVista Integrator is:

- OPC/DDE Server
- Multilin Drivers
- Automatic Event Retrieval
- Automatic Waveform Retrieval

Simplifying Commissioning and Testing

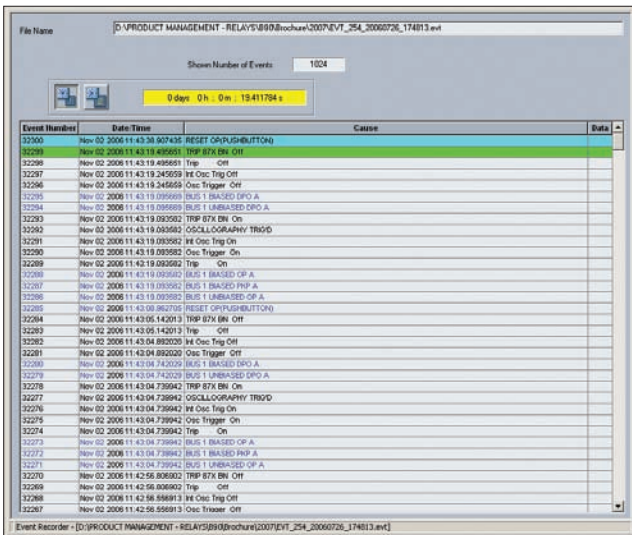

Record the operation of the internal B90 elements and external connected devices with 1ms time-stamped accuracy

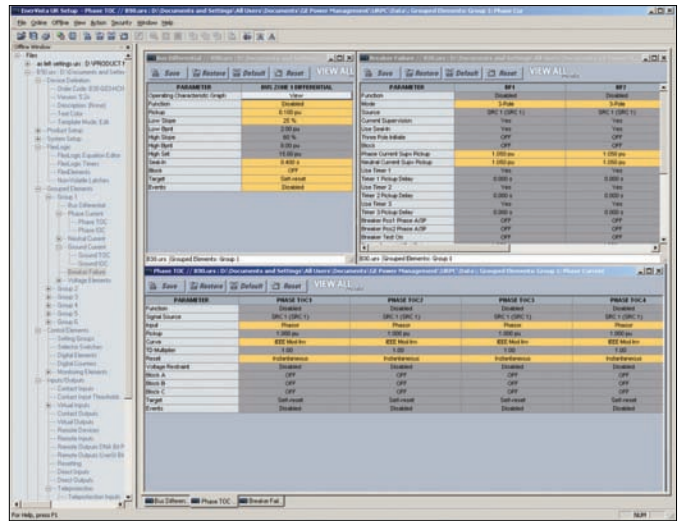

Create B90 Setting File Templates to ensure critical settings are not altered

User Interface

The B90 front panel provides extensive local HMI capabilities. The local display is used for monitoring, status messaging, fault diagnosis, and device configuration. User configurable messages that combine text with live data, can be displayed when user-defined conditions are met.

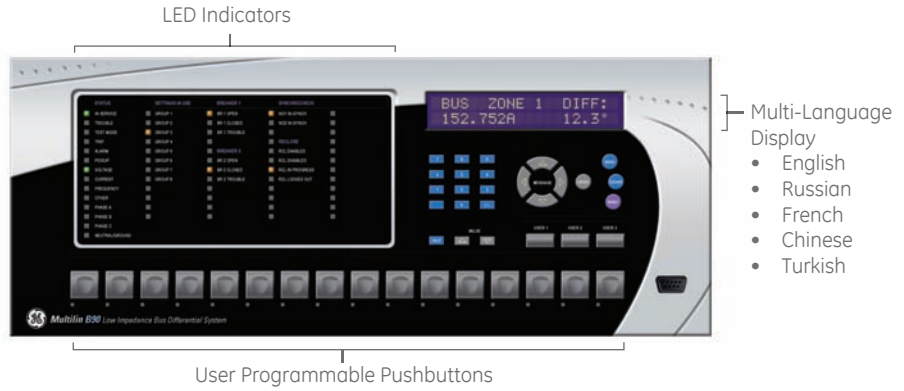

- Multi-Language Display
- English
 - Russian
 - French
 - Chinese
 - Turkish

Typical Wiring

The B90 is a multi-IED protection scheme. Each IED may be ordered with different hardware components and must be wired accordingly. The following drawing illustrates the principles behind a typical B90 wiring.

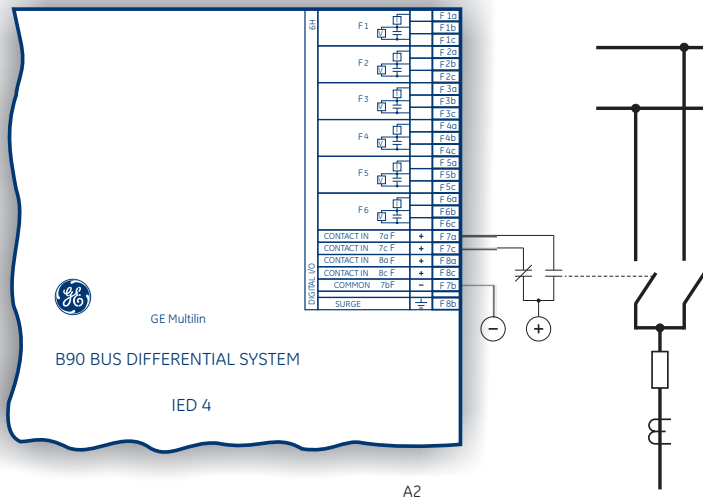
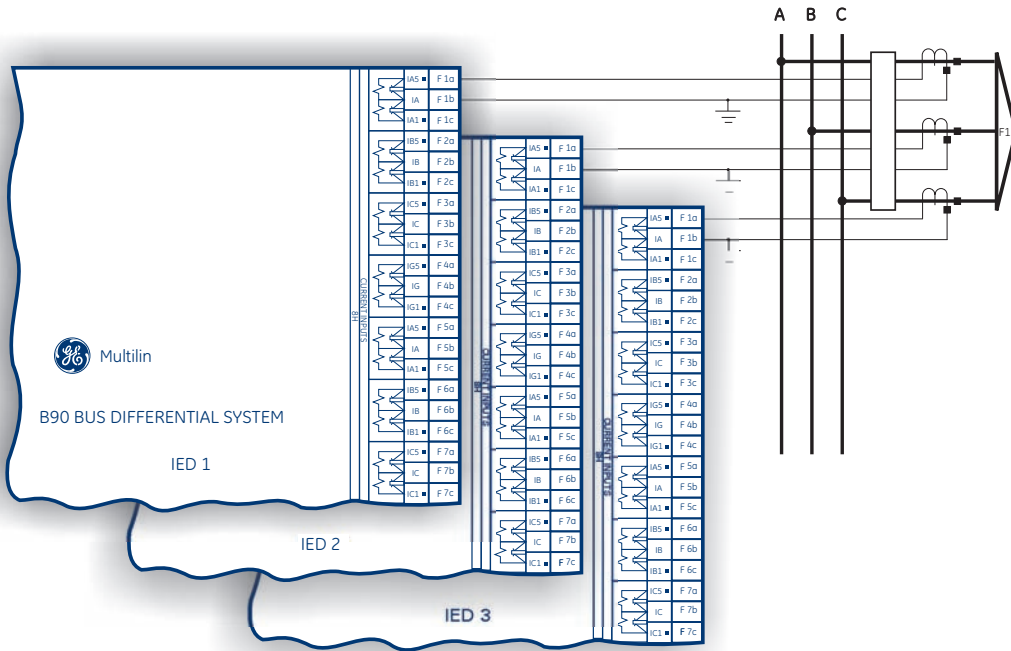

A2

Ordering

(Please Contact GE Energy for Engineered Bus Protection Solutions)

Bus Protection

	B90 - * * * -H * * - F** - H** - L** - N** - S** - U** -W/X **											For full sized horizontal mount						
Base Unit CPU	B90	E	G	H	J	K	N											Base Unit RS485 + RS485 (IEC 61850 option not available) RS485 + 10BaseF RS485 + Redundant 10BaseF RS485 + Multi-mode ST 100BaseFX RS485 + Multi-mode ST Redundant 100BaseFX RS485 + 10/100 BaseT
Software Options		0	1	0	1	2	4	5	6									Without Breaker Failure With Breaker Failure (With Engineered Solution Only) 8-feeders, 4 zones 16-feeders, 4 zones 24-feeders, 4 zones 8-feeders, 4 zones, IEC 61850 16-feeders, 4 zones, IEC 61850 24-feeders, 4 zones, IEC 61850
Mount/ Coating				H	A													Horizontal (19" rack) Horizontal (19" rack) - Harsh Chemical Environment Option
User Interface						K	L	M	N	O	Q	T	U	V	F	W	Y	Enhanced English Front Panel Enhanced English Front Panel with User-Programmable Pushbuttons Enhanced French Front Panel Enhanced French Front Panel with User-Programmable Pushbuttons Enhanced Russian Front Panel Enhanced Russian Front Panel with User-Programmable Pushbuttons Enhanced Chinese Front Panel Enhanced Chinese Front Panel with User-Programmable Pushbuttons Vertical Front Panel with English display Enhanced Turkish Front Panel Enhanced Turkish Front Panel with User-Programmable Pushbuttons
Power Supply						H	L											RH 125 / 250 V AC/DC 125 / 250 V AC/DC with redundant 125/250 V AC/DC 24 - 48 V (DC only)
CT/VT DSP								8F		8F		8F						Standard 4CT/4VT Standard 8CT Standard 7CT/1VT
Digital I/O								XX	XX	XX	XX	XX	XX	XX				No module 4 Solid State (No Monitoring) MOSFET Outputs 4 Solid State (Current w/opt Voltage) MOSFET Outputs 16 Digital Inputs with Auto-Burnish 14 Form-A (No Monitoring) Latchable Outputs 8 Form-A (No Monitoring) Outputs 8 Form-C Outputs 16 Digital Inputs 4 Form-C Outputs, 8 Digital Inputs 8 Fast Form-C Outputs 4 Form-C & 4 Fast Form-C Outputs 2 Form-A (Current w/ opt Voltage) & 2 Form-C Outputs, 8 Digital Inputs 2 Form-A (Current w/ opt Voltage) & 4 Form-C Outputs, 4 Digital Inputs 4 Form-A (Current w/ opt Voltage) Outputs, 8 Digital Inputs 6 Form-A (Current w/ opt Voltage) Outputs, 4 Digital Inputs 2 Form-A (No Monitoring) & 2 Form-C Outputs, 8 Digital Inputs 2 Form-A (No Monitoring) & 4 Form-C Outputs, 4 Digital Inputs 4 Form-A (No Monitoring) Outputs, 8 Digital Inputs 6 Form-A (No Monitoring) Outputs, 4 Digital Inputs
Inter-Relay Communications								6U	6U	6U	6U	6U	6U	6U				7A 820 nm, multi-mode, LED, 1 Channel 7B 1300 nm, multi-mode, LED, 1 Channel 7H 820 nm, multi-mode, LED, 2 Channels 7I 1300 nm, multi-mode, LED, 2 Channels 7S G.703, 2 Channels 7W RS422, 2 Channels 77 IEEE C37.94, 820 nm, multimode, LED, 2 Channel

Accessories for the B90

- UR Applications I Learning CD TRCD-URA1-C-S-1
- Multilink Ethernet Switch ML2400-F-HI-HI-A2-A2-A6-G1
- Viewpoint Engineer VPE-1
- Viewpoint Maintenance VPM-1
- Viewpoint Monitoring IEC 61850 VP-1-61850

Visit www.GEMultilin.com/B90 to:

- View Guideform specifications
- Download the instruction manual
- Review applications notes and support documents
- Buy a B90 online
- View the UR Family brochure



Ordering Note: To view the latest options available for the B90, or to order the UR Classic Front Panel, please visit our online store for more details.