

Multilin™ F60

FEEDER PROTECTION SYSTEM

Advanced Protection, Control and Automation for Distribution Feeders



KEY BENEFITS

- The most flexible protection and control device for distribution feeder applications
- Complete IEC 61850 Process Bus solution providing resource optimization and minimizing total P&C life cycle costs
- Unique and secure downed conductor detection, backed up by many years of field experience
- Flexible load encroachment allows secure operation during heavy load conditions
- Voltage and frequency elements providing load shedding & transfer schemes for increased system uptime and stability
- Advanced automation capabilities for providing customized protection and control solutions
- Application flexibility with multiple I/O options and programmable logic (FlexLogic™)
- Critical Infrastructure Protection through user command logging and dual permission access control
- Advanced fault and disturbance recording, including internal relay operating signals provided thus eliminating the need for redundant recording devices
- Ambient temperature monitoring with alarming when outside temperature exceeds upper thresholds
- Reduced relay to relay wiring and associated installation costs through high-speed inter-relay communications
- Embedded IEC61850 Protocol

APPLICATIONS

- Primary protection and control for feeders on solidly, impedance or resonant (Peterson Coil) grounded systems
- Bus blocking/Interlocking schemes
- Distribution load shedding schemes based on voltage and frequency elements
- High-speed fault detection for arc flash mitigation
- Throw over schemes (bus transfer scheme applications)
- Back-up protection for transmission lines, feeders and transformers
- Distributed Generation (DG) interconnect protection

FEATURES

Protection and Control

- High impedance fault detection (Downed Conductor Detection)
- Directional, time, instantaneous, phase, neutral, negative sequence & ground overcurrent protection
- Load encroachment supervision
- Wattmetric ground fault detection
- Thermal overload, Incipient cable fault detection and broken conductor
- Four-shot autorecloser with synchronism check
- Breaker control and breaker failure
- Abnormal frequency protection (Rate of change, under and over frequency)

Communications

- Networking interfaces – 100Mbit Fiber Optic Ethernet, RS485, RS232, RS422, G.703, IEEE C37.94
- Multiple Protocols - IEC61850, DNP 3.0 Level 2, Modbus TCP/IP, IEC60870-5-104
- Direct I/O – secure, high-speed data exchange between URs, for DG, distribution automation applications
- Embedded Managed Ethernet Switch with 4 - 100 Mbit Fiber optic ports and 2 copper ports

IEC 61850 Process Bus Interface

- Robust communications with up to 8 HardFiber Bricks
- Seamless integration with existing F60 functions
- Redundant architecture for dependability and security

Monitoring and Metering

- Metering - current, voltage, power, energy, frequency and harmonics
- P & M Class synchrophasors of voltage, current and sequence components – 1 to 120 frames/sec
- Oscillography – analog and digital parameters at 64 samples/cycle
- Event Recorder - 1024 time tagged events with 0.5ms scan of digital inputs
- Data Logger - 16 channels with sampling rate up to 1 sample / cycle
- Setting Security Audit Trail for tracking changes to F60 configuration

EnerVista™ Software

- Graphical Logic Designer and Logic Monitor to simplify designing and testing procedures
- Document and software archiving toolset to ensure reference material and device utilities are up-to-date
- EnerVista™ Integrator providing easy integration of data in the F60 into new or existing monitoring and control systems



Protection and Control

The F60 Feeder Protection System provides feeder protection, control, monitoring and metering in an integrated, economical, and compact package. As part of the Universal Relay (UR) Family, the F60 features high performance protection, expandable I/O options, integrated monitoring and metering, high-speed communications, and extensive programming and configuration capabilities.

The F60 incorporates a unique and matured algorithm to detect high impedance faults such as downed conductor detection. It also provides fast and deterministic execution of programmable logic necessary for substation automation applications. Graphical programming tools (ViewPoint Engineer), supported by a library of logic components, make the F60 simple to use and configure.

The F60 has a wide range of protection elements that have many years of proven field experience. Protection and control features includes:

Downed Conductor (Hi-Z) Detection

Fires, injuries, and even fatalities may be caused by a live downed conductor. Unfortunately, these high risk incidences often go undetected by conventional protective relays.

F60 - Protection, Metering, Monitoring and Control

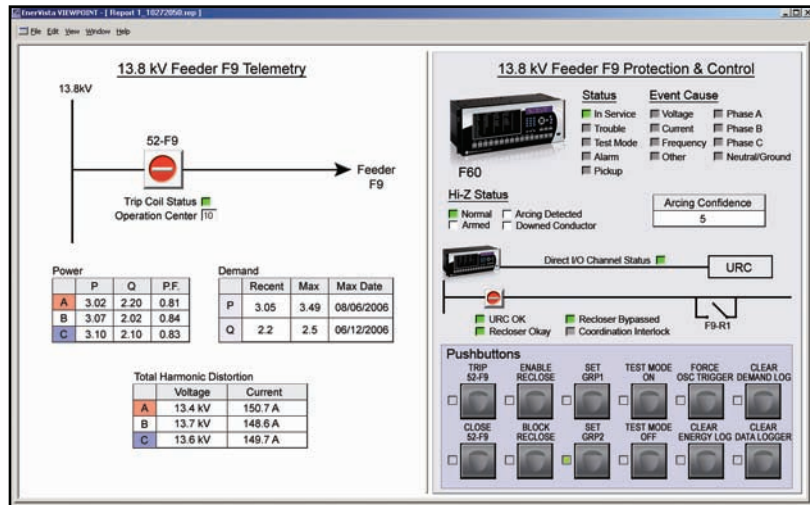

The F60 offers an integrated protection, control, metering and monitoring package that can directly connect into DCS or SCADA monitoring control systems such as View Point Monitoring

The Hi-Z element in the F60, unique to Multilin, provides reliable detection of faults caused by downed conductors. Sophisticated algorithms developed over the past 20 years, detect downed conductors, tree branch contacts, and insulation fault in underground cables. This unique, field proven algorithm incorporates artificial intelligence to maximize dependability. Key benefits of Hi-Z detection in the F60:

- Reliable detection of faults caused by downed conductors

- Fast response to hazardous situations
- Dependable and secure operation using artificial intelligence
- Detection of arcing faults
- Easy integration by addition of a Hi-Z module to a new or existing F60 relay

Directional Overcurrent Protection

The F60 also has Built-in standard IEEE, IEC, IAC and FlexCurves™ overcurrent characteristics (TOC), most commonly used for primary and back-up protection in various protective zones. It has phase

Functional Block Diagram

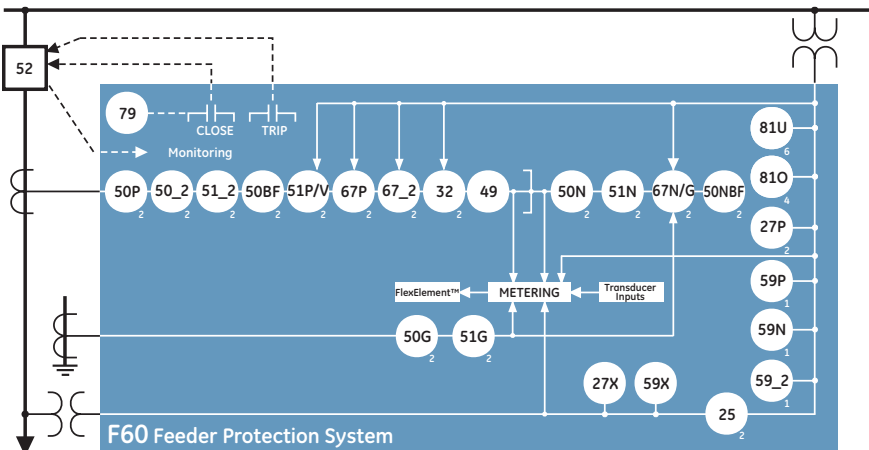

ANSI Device Numbers & Functions

Device Number	Function
25 (2)	Synchronism Check
27P	Phase Undervoltage
27X	Auxiliary Undervoltage
32	Sensitive Directional Power
49	Thermal Overload
50BF/50BNF	Breaker Failure
50DD	Disturbance Detector
50G	Ground Instantaneous Overcurrent
50N	Neutral Instantaneous Overcurrent
50P	Phase Instantaneous Overcurrent
50_2	Negative Sequence Instantaneous Overcurrent
51G	Ground Time Overcurrent
51N	Ground Time Overcurrent
51N (2)	Neutral Time Overcurrent
51P (2)	Phase Time Overcurrent
51_2(2)	Negative Sequence Time Overcurrent
52	AC Circuit Breaker
59N	Neutral Overvoltage
59P	Phase Overvoltage
59X	Auxiliary Overvoltage
59_2	Negative Sequence Overvoltage
67N	Neutral Directional Overcurrent
67P	Phase Directional Overcurrent
67_2	Negative Sequence Directional Overcurrent
79	Automatic Recloser
81O	Overfrequency
81U	Underfrequency

Comprehensive Protection & Control

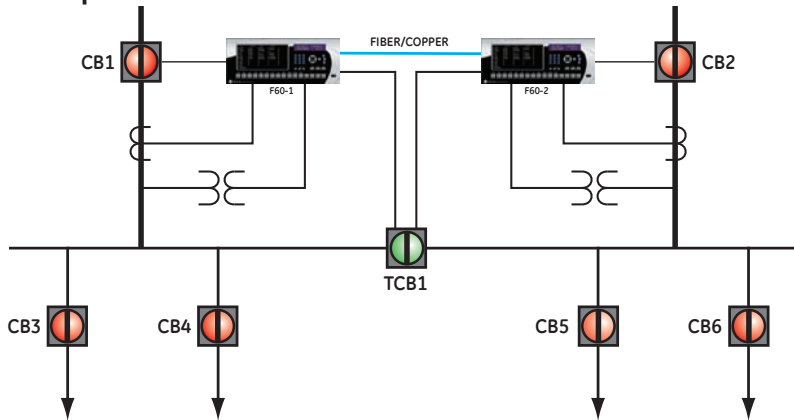

Auto transfer schemes can be implemented using programmable Flexlogic and wiring between relays can be eliminated using peer to peer communication.

IOC elements with separate outputs for each phase. Each TOC element has the following programmable characteristics:

- Pickup current level for trip, alarm, or control
- Choice of 17 curve shapes (including FlexCurves) and curve multipliers
- Instantaneous or linear reset time characteristic to coordinate with upstream transformer damage curves and downstream reclosers and fuses.
- Voltage restraint to increase sensitivity

The majority of distribution systems are either solidly grounded or grounded through a low impedance. Fast fault clearance is required due to the ground fault impact. Following functions are incorporated in the F60 to provide secure ground protection:

- Neutral IOC and TOC
- Ground IOC and TOC

The F60 allows use of directional elements for supervision of ground overcurrent protection elements and provide sensitive tripping for faults in one direction. Typical application for directional overcurrent includes:

- Isolation of faulted feeders in ring bus or parallel feeder arrangements
- Prevention of back-feeding utility source fault from industrial plant generators.

- Sensitive high-speed ground fault protection for transformers

For neutral directional sensing, the residual current of the phase CTs is used as the operating current. For current polarization, a residual CT is used to measure zero-sequence current. For voltage polarization, the calculated or measured zero sequence voltage can be used. The maximum torque angle is programmable.

Load Encroachment

The Load Encroachment function in the F60 provides the capability to manage load growth in feeders. The load encroachment element can be set for the feeder's expected maximum load, reducing the likelihood of false tripping for load conditions while maintaining dependability to trip for legitimate faults.

It allows the phase overcurrent elements to be set to see end-of-line phase faults in heavily loaded feeder applications.

Over/Under Voltage Protection

The F60 includes the following voltage elements:

- Up to 2 phase undervoltage and 1 overvoltage elements
- 1 auxiliary undervoltage/overvoltage element
- 1 neutral overvoltage element

The following are some of the key applications where voltage elements can be used:

- Source transfer schemes
- Load shedding schemes
- Back up capacitor bank protection and control
- Backup motor protection to prevent automatic restart.

Abnormal Frequency Protection

The F60 offers overfrequency and underfrequency elements to improve network (grid) stability using voltage or frequency based load shedding techniques. The F60 can be integrated into a communications network containing N60 Network Stability relays to implement wide area intelligent load shedding schemes. It also provides back up protection when protecting feeders and other frequency sensitive power equipment.

Frequency Rate of Change Protection

Frequency rate of change (df/dt) elements included in the F60 to provide protection against system disturbances through load shedding and to provide anti-islanding protection for distributed generator interconnections.

Cold Load Pickup

A cold load condition can be caused by a prolonged outage of the load, by opening of the circuit breaker, or by a loss of supply even if the breaker remains closed (cyclic loads like HVAC, refrigeration systems). F60 can automatically detect conditions that would lead to cold load pickup and selectively block protection elements for security during feeder energization.

Wattmetric Ground Fault Protection

A sensitive wattmetric zero-sequence directional function can be used on isolated or resonant (Petersen coil) grounded, low-resistance grounded and solidly grounded systems to detect ground faults.

This function determines the presence and direction of ground faults by measuring the value and direction of zero-sequence power. This flexible element responds

FlexLogic™ Designer

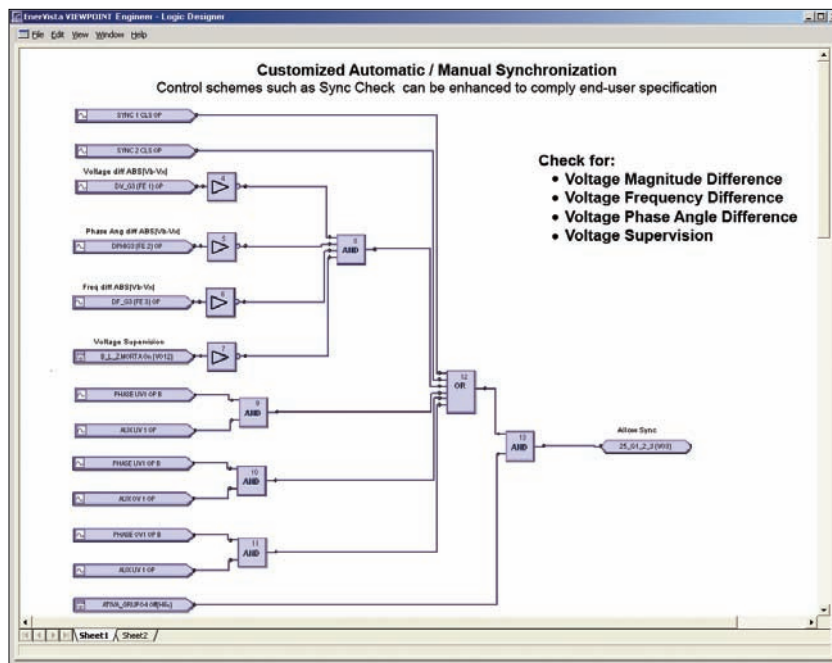

Flexlogic allows the F60 to operate and control breakers and other auxiliary devices needed to fit most feeder protection schemes and applications.

to power derived from zero-sequence voltage and current in a direction specified by the element characteristic angle. Power can be selected as active, reactive, or apparent. Therefore, the element may be used to sense either forward or reverse ground faults

Autorecloser

Two autoreclose elements are provided for use with distribution lines in three-pole tripping schemes with up to two breakers. Up to four selectable recloser “shots” are possible prior to locking out.

Breaker Failure and Control

The F60 provides the required elements to perform two independent breaker failure functions. The F60 can provide independent breaker failure protection for both breakers on a feeder with a breaker-and-a-half or ring bus terminal.

The relay also provides for control of one or two breakers from faceplate pushbuttons, remote communications or contact inputs. A breaker position can be indicated by LEDs on the faceplate.

IEC 61850 Process Bus

The IEC 61850 Process Bus module is designed to interface with the Multilin HardFiber System, allowing bi-directional IEC 61850 fiber optic communications. The HardFiber System is designed to integrate seamlessly with the existing Universal Relay applications, including protection functions, FlexLogic, metering and communications.

The Multilin HardFiber System offers the following benefits:

- Communicates using open standard IEC 61850 messaging
- Drastically reduces P&C design, installation and testing labor by eliminating individual copper terminations
- Integrates with existing F60's by replacing traditional CT/VT inputs with IEC 61850 Process Bus module
- Does not introduce new Cyber Security concerns

Visit the HardFiber System product page on the GE Digital Energy web site for more details.

Advanced Automation

The F60 incorporates advanced automation features including powerful FlexLogic™ programmable logic, communication, and SCADA capabilities that far surpass what is found in the average feeder relay. The F60 integrates seamlessly with other UR relays for complete system protection, including the unit and auxiliary transformers, and balance of plant protection.

FlexLogic™

FlexLogic™ is the powerful UR-platform programming logic engine that provides the ability of creating customized protection and control schemes thereby minimizing the need, and the associated costs, of auxiliary components and wiring. Using FlexLogic™, the F60 can be programmed to provide required tripping logic along with custom scheme logic for auto transfer schemes (Main-Tie-Main), loadshedding based on frequency, voltage and communication, loop restoration schemes, other remedial action schemes and dynamic setting group changes.

Scalable Hardware

The F60 is available with a multitude of I/O configurations to suit the most demanding application needs. The expandable modular design allows for easy configuration and future upgrades.

- Flexible, modular I/O covering a broad range of input signals and tripping schemes
- Types of digital outputs include trip-rated Form-A and Solid State Relay (SSR) mechanically latching, and Form-C outputs
- RTDs and DCmA inputs are available to monitor equipment parameters such as temperature & pressure

Monitoring and Metering

The F60 includes high accuracy metering and recording for all AC signals. Voltage, current, and power metering are built into the relay as a standard feature. Current and voltage parameters are available as total RMS magnitude, and as fundamental frequency magnitude and

angle. The F60 also measures up to the 25th harmonic on voltage and current, suitable for power quality applications.

Fault and Disturbance Recording

The advanced disturbance and event recording features within the F60 can significantly reduce the time needed for postmortem analysis of power system events and creation of regulatory reports. Recording functions include:

- Sequence of Event (SOE)
 - 1024 time stamped events
- Oscillography,
 - 64 digital & up to 40 Analog channels
- Data Logger, disturbance recording
 - 16 channels up to 1 sample / cycle / channel
- Fault Reports
 - Powerful summary report of pre-fault and fault values
- Extensive breaker info (continuous coil monitor, arcing current, operating time, operation counter for asset management)

The very high sampling rates and large amount of storage space available for data recording in the F60 can eliminate the need for installing costly standalone recording equipment.

Advanced Device Health Diagnostics

The F60 performs comprehensive device health diagnostic tests during startup

and continuously at runtime to test its own major functions and critical hardware. These diagnostic tests monitor for conditions that could impact security and availability of protection, and present device status via SCADA communications and front panel display. Providing continuous monitoring and early detection of possible issues helps improve system uptime.

- Comprehensive device health diagnostic performed during startup
- Monitors the CT/VT input circuitry to validate the integrity of all signals

Communications

The F60 provides advanced communications technologies for remote data and engineering access, making it easy and flexible to use and integrate into new and existing infrastructures. Direct support for fiber optic Ethernet provides high-bandwidth communications allowing for low-latency controls and high-speed file transfers of relay fault and event record information. The available redundant Ethernet option and the embedded managed Ethernet switch provide the means of creating fault tolerant communication architectures in an easy, cost-effective manner without the need for intermediary communication hardware.

The F60 supports the most popular industry standard protocols enabling easy, direct integration into DCS and SCADA systems.

- IEC61850
- DNP3.0
- Ethernet Global Data (EGD)
- IEC 60870-5-104
- Modbus RTU, Modbus TCP/IP

Interoperability with Embedded IEC 61850

Use the F60 with integrated IEC 61850 to lower costs associated with feeders protection, control and automation. GE Energy's leadership in IEC 61850 comes from thousands of installed devices and follows on seven years of development experience with UCA 2.0.

- Replace expensive copper wiring between devices with direct transfer of data using GOOSE messaging for transfer tripping, interlocking schemes, loop restoration, and loadshedding schemes.
- Configure systems based on IEC61850 and also monitor and troubleshoot them in real-time with EnerVista™ Viewpoint Engineer
- Integrate Multilin IEDs and generic IEC61850-compliant devices seamlessly in EnerVista™ Viewpoint Monitoring

Direct I/O Messaging

Direct I/O allows for sharing of high-speed digital information between multiple UR relays via direct back-to-back connections or multiplexed through a standard DS0 multiplexer channel bank. Regardless of the connection method, Direct I/O provides continuous real-time channel monitoring that supplies diagnostics information on channel health.

Direct I/O provides superior relay-to-relay communications that can be used in advanced interlocking, generation rejection and other special protection schemes.

- Communication with up to 16 UR relays in single or redundant rings rather than strictly limited to simplistic point-to-point configurations between two devices
- Connect to standard DS0 channel banks through standard RS422, G.703 or IEEE C37.94 interfaces or via direct fiber optic connections

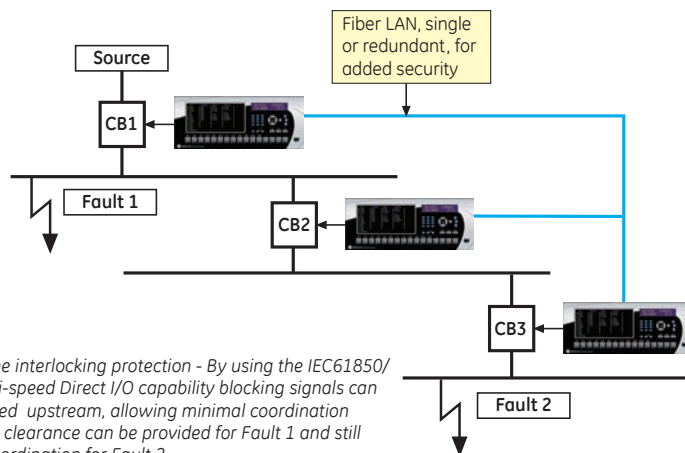

Reverse zone interlocking protection - By using the IEC61850/GOOSE or hi-speed Direct I/O capability blocking signals can be transferred upstream, allowing minimal coordination delays. Fast clearance can be provided for Fault 1 and still maintain coordination for Fault 2.

- No external or handheld tester required to provide channel diagnostic information

Multi-Language

The F60 supports English, French, Russian, Chinese and Turkish Languages on the front panel, EnerVista™ setup software, and product manual. Easily switch between English and an additional language on the local displays without uploading new firmware.

EnerVista™ Software

The EnerVista™ Suite is an industry-leading set of software programs that simplifies every aspect of using the F60 relay. The EnerVista™ suite provides all the tools to monitor the status of your the protected asset, maintain the relay, and integrate information measured by the F60 into DCS or SCADA monitoring systems. Convenient COMTRADE and Sequence of Events viewers are an integral part of the UR Setup software included with every UR relay, to carry out postmortem event analysis and to ensure proper protection of system operation.

EnerVista™ Launchpad

EnerVista™ Launchpad is a powerful software package that provides users with all of the setup and support tools needed for configuring and maintaining Multilin products. The setup software within Launchpad allows configuring devices in real-time by communicating using serial, Ethernet, or modem connections, or offline by creating setting files to be sent to devices at a later time.

Included in Launchpad is a document archiving and management system that ensures critical documentation is up-to-date and available when needed. Documents made available include:

- Manuals
- Application Notes
- Guideform Specifications
- Brochures
- Wiring Diagrams
- FAQ's
- Service Bulletins

Viewpoint Monitoring

Viewpoint Monitoring is a simple-to-use and full-featured monitoring and data recording software package for small systems. Viewpoint Monitoring provides a complete HMI package with the following functionality:

- Plug-&-Play Device Monitoring
- System Single-Line Monitoring & Control
- Annunciator Alarm Screens
- Trending Reports
- Automatic Event Retrieval
- Automatic Waveform Retrieval

Viewpoint Engineer

Viewpoint Engineer is a set of powerful tools that will allow the configuration and testing of UR relays at a system level in an easy-to-use graphical drag-and-drop environment. Viewpoint Engineer provides the following configuration and commissioning utilities:

- Graphical Logic Designer
- Graphical System Designer
- Graphical Logic Monitor
- Graphical System Monitor

Power System Troubleshooting

The F60 contains many tools and reports that simplify and reduce the amount of time required for troubleshooting power system events, increase uptime and reduce loss of production.

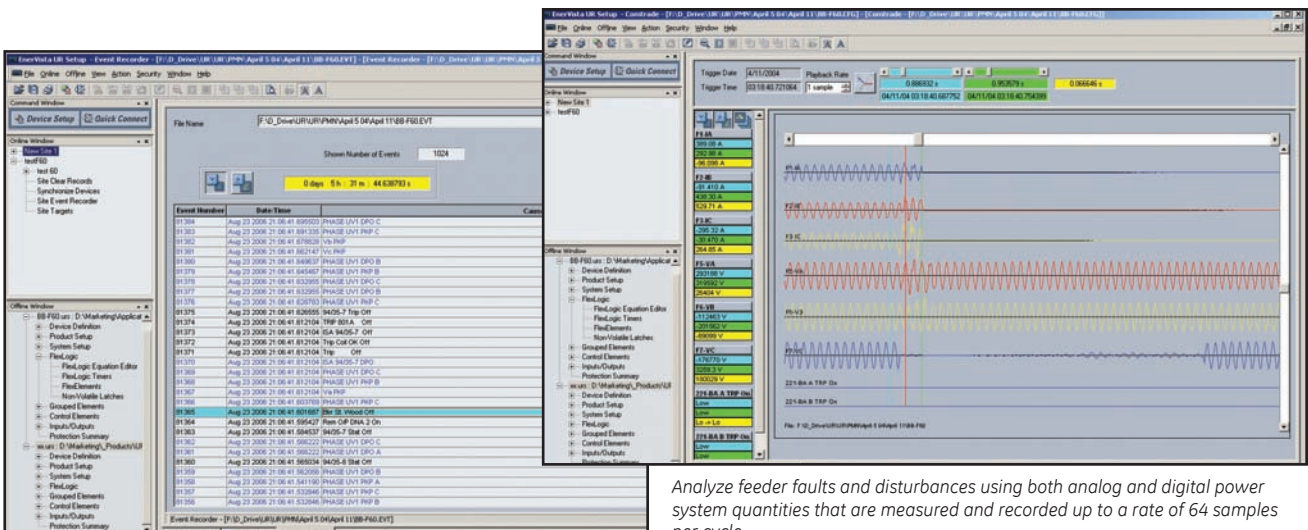

Record the operation of the internal F60 elements and external connected devices with 1ms time-stamped accuracy to identify the Sequence of Operation of station devices during faults and disturbances.

Analyze feeder faults and disturbances using both analog and digital power system quantities that are measured and recorded up to a rate of 64 samples per cycle.

Typical Wiring

Viewpoint Maintenance

Viewpoint Maintenance provides tools that will create reports on the operating status of the relay, simplify the steps to download fault and event data, and reduce the work required for cyber-security compliance audits. Tools available in Viewpoint Maintenance include:

- Settings Security Audit Report
- Device Health Report
- Single Click Fault Data Retrieval

EnerVista™ Integrator

EnerVista™ Integrator is a toolkit that allows seamless integration of Multilin devices into new or existing automation systems. Included in EnerVista™ Integrator is:

- OPC/DDE Server
- GMultilin Drivers
- Automatic Event Retrieval
- Automatic Waveform Retrieval

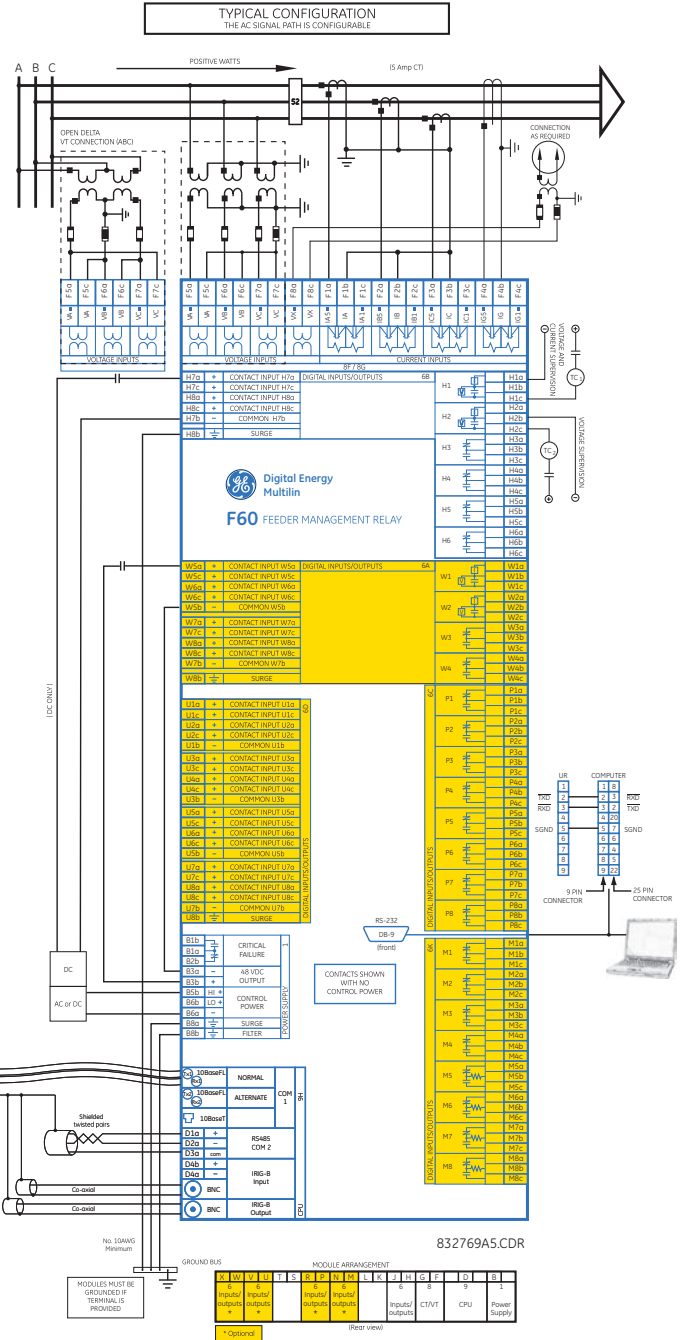

Distribution Feeder Protection

User Interface

The F60 front panel provides extensive local HMI capabilities. The local display is used for monitoring, status messaging, fault diagnosis, and device configuration. User configurable messages that combine text with live data, can be displayed when user-defined conditions are met.



Ordering

Distribution Feeder Protection

	F60	-	*	**	-	H	*	*	-	F	**	-	H	**	-	M	**	-	P	**	-	U	**	-	W	**	For Full Sized Horizontal Mount
Base Unit	F60																									Base Unit	
CPU			E	G	H	J	K	N	S																	RS485 + RS485 (IEC61850 option not available)	
Software Options			00	03	06	07																				RS485 + Multi-mode ST 10BaseF	
Mount / Coating							H	A	V	B																RS485 + Multi-mode ST Redundant 10BaseF	
User Interface										K	L	M	N	O	T	U	V	F	W	Y							RS485 + Multi-mode ST 100BaseFX
Power Supply							H	L																		RS485 + Multi-mode ST Redundant 100BaseFX	
CT/VT DSP										8F	8G	8H	8J	8L	8M	8N	8R										RS485 + 10/100 BaseT
IEC 61850 Process Bus																										RS485 + 6 port, 100 Mbps, Managed Ethernet Switch	
Digital I/O																										No Software Options	
Transducer I/O																										IEC61850	
Inter-Relay Communications																										PMU	
																										IEC61850 + PMU	
																										Horizontal (19" rack) - Standard	
																										Horizontal (19" rack) - Harsh Chemical Environment Option	
																										Vertical (3/4 size) - Standard	
																										Vertical (3/4 size) - Harsh Chemical Environment Option	
																										Enhanced English Front Panel	
																										Enhanced English Front Panel with User-Programmable Pushbuttons	
																										Enhanced French Front Panel	
																										Enhanced French Front Panel with User-Programmable Pushbuttons	
																										Enhanced Russian Front Panel	
																										Enhanced Russian Front Panel with User-Programmable Pushbuttons	
																										Enhanced Chinese Front Panel	
																										Enhanced Chinese Front Panel with User-Programmable Pushbuttons	
																										Vertical Front Panel with English display	
																										Enhanced Turkish Front Panel	
																										Enhanced Turkish Front Panel with User-Programmable Pushbuttons	
																										125 / 250 V AC/DC	
																										125/250 V AC/DC with redundant 125/250 V AC/DC power supply	
																										24 - 48 V (DC only)	
																										Standard 4CT/4VT	
																										Sensitive Ground 4CT/4VT	
																										Standard 8CT	
																										Sensitive Ground 8CT	
																										Standard 4CT/4VT w/ enhanced diagnostics	
																										Sensitive Ground 4CT/4VT w/ enhanced diagnostics	
																										Standard 8CT w/ enhanced diagnostics	
																										Sensitive Ground 8CT w/ enhanced diagnostics	
																										HI-Z 4CT (high impedance fault detection)	
																										8 Port IEC 61850 Process Bus Module	
																										No module	
																										4 Solid State (No Monitoring) MOSFET Outputs	
																										4 Solid State (Current w/opt Voltage) MOSFET Outputs	
																										16 Digital Inputs with Auto-Burnish	
																										14 Form-A (No Monitoring) Latchable Outputs	
																										8 Form-A (No Monitoring) Outputs	
																										8 Form-C Outputs	
																										16 Digital Inputs	
																										4 Form-C Outputs, 8 Digital Inputs	
																										8 Fast Form-C Outputs	
																										4 Form-C & 4 Fast Form-C Outputs	
																										2 Form-A (Current w/ opt Voltage) & 2 Form-C Outputs, 8 Digital Inputs	
																										2 Form-A (Current w/ opt Voltage) & 4 Form-C Outputs, 4 Digital Inputs	
																										4 Form-A (Current w/ opt Voltage) Outputs, 8 Digital Inputs	
																										6 Form-A (Current w/ opt Voltage) Outputs, 4 Digital Inputs	
																										2 Form-A (No Monitoring) & 2 Form-C Outputs, 8 Digital Inputs	
																										2 Form-A (No Monitoring) & 4 Form-C Outputs, 4 Digital Inputs	
																										4 Form-A (No Monitoring) Outputs, 8 Digital Inputs	
																										6 Form-A (No Monitoring) Outputs, 4 Digital Inputs	
																										2 Form-A (Cur w/ opt Volt) 1 Form-C Output, 2 Latching Outputs, 8 Digital Inputs	
																										8 RTD Inputs	
																										4 dcma Inputs, 4 RTD Inputs	
																										8 dcma Inputs	
																										820 nm, multi-mode, LED, 1 Channel	
																										1300 nm, multi-mode, LED, 1 Channel	
																										1300 nm, single-mode, ELED, 1 Channel	
																										820 nm, multi-mode, LED, 2 Channels	
																										1300 nm, multi-mode, LED, 2 Channels	
																										1300 nm, single-mode, ELED, 2 Channels	
																										G.703, 2 Channels	
																										RS422, 2 Channels	
																										IEEE C37.94, 820 nm, multimode, LED, 1 Channel	
																										IEEE C37.94, 820 nm, multimode, LED, 2 Channel	
																										6 port, 100 Mbps, Managed Ethernet Switch, HI (125/250V AC/DC)	
																										6 port, 100 Mbps, Managed Ethernet Switch, LO (24-48 Vdc)	

Accessories for the F60

- | | |
|---------------------------------|----------------------------|
| • UR Applications I Learning CD | TRCD-URA1-C-S-1 |
| • Multilink Ethernet Switch | ML2400-F-HI-HI-A2-A2-A6-G1 |
| • Viewpoint Engineer | VPE-1 |
| • Viewpoint Maintenance | VPM-1 |
| • Viewpoint Monitoring IEC61850 | VP-1-61850 |