

# BUS 1000/2000

Busbar Protection



*Solid state, high-speed modular busbar protection system.*

8

## Features and Benefits

- Measuring function supervision
- Modular design
- Metering, monitoring, event recording, waveform capture and IRIG-B synchronization (BUS 2000)
- Highly sensitive differential overcurrent function
- Compatible with existing installations
- Test points for ease of installation
- Optional breaker failure function
- Optional overcurrent units for individual trip supervision
- Optional test system

## Applications

- Detection of phase-to-ground faults on high voltage busbar installations of any voltage

## Protection and Control

- Three-phase differential overcurrent with percentage restraint
- Stabilizing resistors

## Monitoring and Metering

- Event recording
- Current differential oscillography

## User Interfaces

- Two RS232 communication ports



## Protection

The BUS 1000/2000 is a solid state, high-speed protection system for phase-to-phase and phase-to-ground faults on busbar installations of any voltage. This relay provides advanced protection which includes:

### Differential Overcurrent

The main protective function of the BUS is the three-phase differential overcurrent relay with percentage restraint and stabilizing resistors.

For high-magnitude external faults, a completely balanced differential circuit is nearly impossible to achieve due to the differences in the CT. To prevent operation on these unbalances, a current differential relay with percentage restraint is used.

The differential current is defined as the difference of the restraint currents. As the through current increases, the level of differential current must increase to operate the relay.

The stability of the protection means that there is no false operation under severe external faults. Stability is assured by selecting the proper combination of percentage restraint and stabilizing resistor values depending only on the total resistance of the saturated circuit seen from the relay. The restraint percentage may be set from 0.5 to 0.8 and the stabilizing resistor is set to 250 Ω.

A very sensitive differential overcurrent function provides an alarm and blocks the trip output if the measuring function inputs are accidentally disconnected during normal operation.

The operating characteristics of the BUS 1000/2000 allow selective and high speed detection and clearing of any type of fault which occurs inside the protected zone.

### Optional Breaker Failure

This function (per line) is associated with differential protection and

can be provided in the same package. With an analog breaker option, the pickup can be set from 0.2 to 3.3 A. When reset time is less than 12 ms the discrimination time is 100 to 730 ms. Digital breaker failure is possible by means of a DBF unit.

### Optional Overcurrent Units

Overcurrent units for individual trip supervision of the breakers can be provided in the same package. Pickup can be set from 0.2 to 3.3 A. This option is only available with the breaker failure option selected.

### Outputs

The BUS 1000/2000 has independent trip outputs per line and independent signaling outputs

for trip, alarm and block per bar. The operating time of an output relay is less than 10 ms.

## Monitoring and Metering

The BUS 2000 features a monitoring module containing an event recorder, LCD display, RS232 or fiber optic communications interface and an IRIG-B time synchronization. This unit provides and stores relevant information which can be used for post-fault analysis. The monitoring unit is mounted in a 19" rack case.

### Measuring Function

The measuring function is supervised for error-free operation.

## Typical Wiring

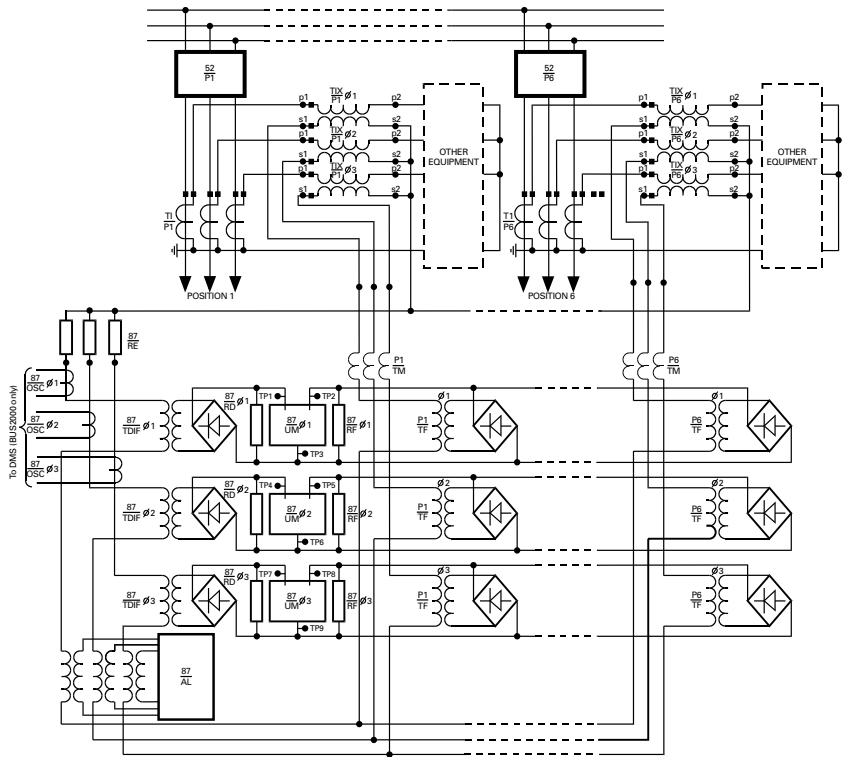

LEGEND:			
S2	Power circuit breaker	RE	Stabilizing resistor
P1 ... P6	Positions 1 to 6	RD	Differential voltage resistor
T1	Main current transformer	RF	Restraint voltage resistor
TDX	Auxiliary current transformer	UM	Measuring unit
S7	Differential unit	AL	Alarm unit
		TDIF	Differential circuit input current transformer
		TF	Restraint circuits input current transformer
		TM	Transducer for input current measuring studs
		TP1 ... TP9	Restraint and operating quantities test studs
		S7DISP	Trip relays

719750A3.CDR

## Features

The BUS comes with state-of-the-art testing and design features:

### Testing

The modules have test points for line currents, restraint and differential magnitudes for ease of installation and maintenance. An optional test system may be used to check the operation and alarm functions under normal operating conditions.

### Modular Design

The modular design allows systems to be adapted to the specific characteristics of the busbar to be protected. Depending on the application, the protection system is located in either standard 19" rack cases, or in ready to install cabinets.

## Dimensions

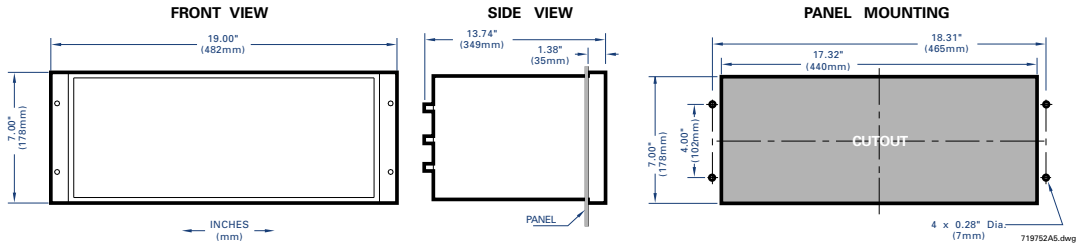

## Guideform Specifications

For an electronic version of the BUS guideform specifications, please visit: [www.GEindustrial.com/Multilin/specs](http://www.GEindustrial.com/Multilin/specs), fax your request to 905-201-2098 or email to [literature.multilin@indsys.ge.com](mailto:literature.multilin@indsys.ge.com).



### Accessories

- Cabinet for BUS 2000 19" racks
- Test system

## BUS Technical Specifications

PROTECTION	
STABILIZING RESISTOR 250 Ω	
ALARM FUNCTION	
Pickup:	0.027 A
Operation time:	10 sec
BREAKER FAILURE (OPTION)	
Pickup:	0.2 – 3.3 A
Reset time:	<12 ms
First Stage timer:	100 – 730 ms
2nd and 3rd stage:	Upon request

METERING	
Current:	$I_n = 1 A$
Thermal ratings:	
Per line input:	
Continuous:	$2 \times I_n$
Three sec:	$50 \times I_n$
One sec:	$100 \times I_n$
Total current flow through the busbar:	
Continuous:	$20 \times I_n$

MONITORING	
SENSITIVITY (FOR INTERNAL FAULTS) Adjustable from 0.2 – 2.0 A	
OPERATING TIME (INCLUDING OUTPUT RELAY) <10 ms	

APPROVALS	
CE Compliant	UL - UL listed for the USA and Canada

\*Specifications subject to change without notice.

INPUTS	
LINE CURRENT TRANSFORMERS REQUIREMENTS Relation between maximum and minimum current transformer ratio on all positions connected to the same busbar: 10 max Maximum saturation voltage required (for $I_n = 5 A$ ): 100 V	

INTERMEDIATE CURRENT TRANSFORMERS	
Standard ratios:	5:2 5:1.33 5:1 5:0.5 5:0.2
Other ratios, according to application, available.	

DC BURDENS		
	125 VDC systems (mA)	
	Normal	Tripped
Single bus system	280	670
Trip output (per line)	—	65
Line supervision and breaker failure units (per line)	70	140

TYPE TESTS	
Insulation test voltage:	2 kV, 50/60 Hz, one min
Impulse voltage withstand:	5 kV peak, 1.2/50 μsec, 0.5 J
Interference test withstand:	ANSI/IEEE C37.90 and IEC 255-5

ENVIRONMENTAL	
Ambient temperature range:	
Storage:	-40° C to +70° C (-40° C also available)
Operation:	-20° C to +65° C

## Ordering

The BUS 1000/2000 is a modular system formed by individual functions and combinations. (The model number must be confirmed by the manufacturer.)

<b>BUS</b>	<b>* * * * *</b>	<b>* * * * *</b>	<b>00</b>	
<b>BUS</b>				BUS system in standard 19" racks
1				Without numerical monitorization module
2				With numerical monitorization module
1				Single busbar
2				Double busbar
	**			Specify the number of lines + bus coupler (two digits) (Add 1 for bus couplers in case of double busbar)
		A		Without cabinet
		D		In a 787" x 315" cabinet (2000mm x 800mm x 800 mm)
		1		Without BF
		2		With analog BF
		3		With digital BF
			2	With test rack and short circuitable resistors
			3	Without test rack and short circuitable resistors
			1	50 Hz
			2	60 Hz
			C	Auxiliary voltage 125 VDC
			D	Auxiliary voltage 250 VDC
			E	Auxiliary voltage 220 VDC
			F	Auxiliary voltage 110 VDC

Auxiliary CTs are loose supplied unless otherwise specified.