



G650

GENERATOR PROTECTION & CONTROL SYSTEM

Protection, control and monitoring for generator interconnection

KEY BENEFITS

- Complete distributed generator interconnection protection with two protection options, Basic Protection and Enhanced Protection, to fit your generator protection requirements.
- Preconfigured with Logic for standard Tripping and Closing operation.
- Reduce installation space requirements with a compact design incorporating protection, control, programmable pushbuttons, programmable LEDs, and communication interfaces
- Reduced system event analyzing time and cost through integrated Sequence of Event reports, Oscillography recording, and Trending files.
- Flexible and cost effective control for complex systems through the use of IEC61131 compatible programmable logic to customize the relay's operation
- Minimized communication down time through reliable redundant Ethernet Communication ports

APPLICATIONS

- Protection of small to medium sized Induction or Synchronous Generators
- Stand-alone or component in automated substation control system
- Distributed generation and interconnection protection, management, and control where programmable logic is a requirement to interact with prime mover control system

FEATURES

Basic Protection Option

- Phase, Neutral, Ground and Negative Sequence TOC and IOC
- Neutral and Ground Directional Overcurrent
- Voltage Restraint Overcurrent
- Phase Under and Overvoltage, Neutral and Ground Overvoltage
- Directional Power
- Under and Overfrequency, and Frequency Rate of Change
- Generator Thermal Model
- Generator Current unbalance
- Loss of Excitation
- Inadvertent Generator Energization

Enhanced Protection Option (Includes all Basic functions)

- Sensitive Ground Overcurrent
- Volts/Hz
- Power Factor limiting
- Vector surge loss of mains detection
- Breaker Failure
- VT Fuse failure
- Restricted Ground Fault

Monitoring and Metering

- Current, voltage, power, power factor, frequency metering, demand
- Breaker condition monitoring including breaker arcing current (I_{2t}) trip counters, and trip circuit monitoring
- Event Recorder - 479 time tagged events, with 1ms time resolution
- High resolution oscillography and Data Logger, with programmable sampling rate
- Fault locator, record of last 10 faults

Communications

- Standard serial interface with RS232, optional USB port - up to 115,200 bps
- Optional second rear RS485 or serial fiber plastic or glass fiber optic port
- Ethernet Ports - 10/100 Base TX, 100 Base FX with ST connectors, options for redundancy available
- Multiple protocols - ModBus™ RTU and over TCP/IP, DNP 3.0 Level 2, IEC 60870-5-104, Http, and ftp.

EnerVista™ Software

- State of the art software for configuration and commissioning GE Multilin products
- Document and software archiving toolset to ensure reference material and device utilities are up-to-date
- EnerVista™ Integrator providing easy integration of data in the G650 into new or existing monitoring and control systems



Digital Energy
Multilin

Protection and Control

The G650 is a distributed generation protection and control system designed to protect and control small to medium size generators, as well as to operate as a distributed generation interconnection protection system. All the elements required by international standards to protect a distributed generator have been integrated into a single package for a cost-effective, reliable and simple solution. Additionally, the enhance fault recording and communications capability found in the G650 truly make this relay a global leader in the Generator Interconnect marketplace. As part of the 650 Family, the G650 provides superior protection and control that includes:

Loss of Mains

The Loss of Mains element has a fast decoupling time that can be used to protect synchronous generators in case of a mains failure. The angle displacement setting is selectable between 2 and 22°. The Loss of Mains Element may be applied in two different operating modes:

- Trip the Generator breaker in cases of failure in the interconnecting feeder.

- Trip the incoming feeder breaker in cases where the generator must remain on line to maintain service to essential loads.

Voltage Protection

The following voltage protection elements are provided:

- Phase undervoltage
- Phase overvoltage
- Negative Sequence overvoltage
- Zero Sequence overvoltage
- Additional under and overvoltage elements

Sensitive Directional Power

The Directional Power element responds to three-phase active power and is designed for reverse power (32R) and low forward power (32LF) applications for synchronous machines or interconnections involving cogeneration. The relay measures three-phase power using either wye-connected or delta-connected VTs.

If the generator accelerates via the power system rather than the prime mover, the reverse power element may be prevented from operating for a selectable period of time.

The low forward power element is active only when the generator is online. The pickup level is set lower than the expected generator loading during normal operations.

Power Factor Limiting

This element allows the user to protect the generator against power factor values outside configurable limits. The element has two stages that can be used as alarm or as a trip for lead and lag conditions.

Frequency Elements

The G650 provides under and overfrequency elements supervised by an independently adjustable voltage element. Use the frequency rate of change (df/dt) element included in the G650 to provide protection against system disturbances through load shedding and to provide anti-islanding protection. This element monitors the speed by which the frequency changes in any direction, through voltage, current and frequency supervision.

Overexcitation Protection

Provided through a Volts/Hertz function with programmable inverse time characteristic.

Functional Block Diagram

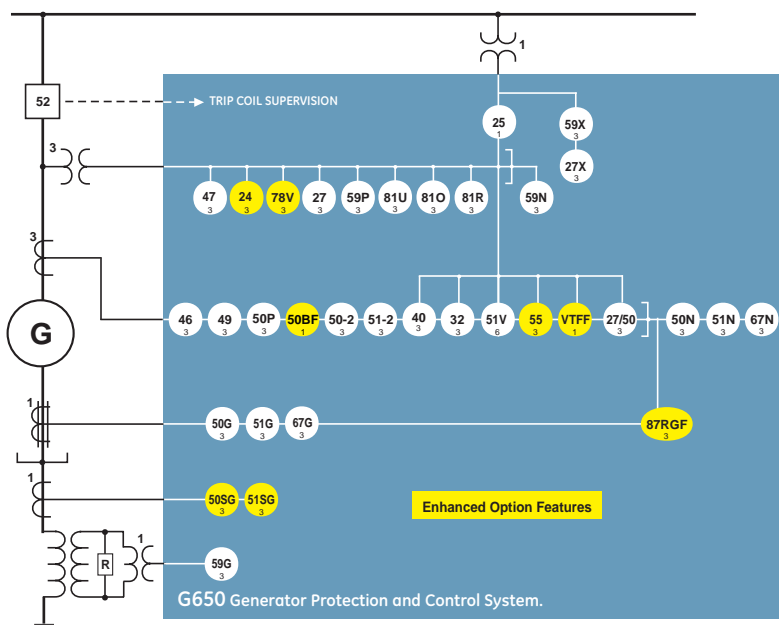

ANSI Device Numbers & Functions

Device Number	Function
27P	Phase Undervoltage
27X	Auxiliary Undervoltage
32R	Reverse Power
32L	Low Forward Power
46	Stator Current Unbalance
47	Phase Reversal
50BF	Breaker Failure
50P	Phase Instantaneous Overcurrent
50N	Neutral Instantaneous Overcurrent
50G	Ground Instantaneous Overcurrent
51P	Phase Time Overcurrent
51N	Neutral Time Overcurrent
51G	Ground Time Overcurrent
51V	Voltage Restrained Time Overcurrent
59P	Phase Overvoltage
59X	Auxiliary Overvoltage
59N	Neutral Overvoltage
67P	Phase Directional Overcurrent
67N	Neutral Directional Overcurrent
67G	Ground Directional Overcurrent
60V	Voltage Unbalance
81O	Overfrequency
81U	Underfrequency
VTF	VT Fuse Fail

Loss of Excitation

Use the G650 for the detection of the loss of excitation of synchronous generators, and to automatically remove the generator from service. Loss of excitation can be damaging to the machine, and/or detrimental to the operation of the system. It is recommended that loss-of-excitation protection be considered for all synchronous generators. Protective relays are applied as backup protection for excitation systems, which in most cases include minimum-excitation limiters to prevent under-excitation.

An offset mho characteristic was chosen to provide selectivity between loss of excitation and other normal or abnormal conditions that may exist on the system. The element provides two-stage impedance based protection and responds to the positive sequence voltage and current.

Breaker Failure

The breaker failure function determines if a breaker that was signaled to trip has not cleared a fault within a definite time, so further tripping action may be performed. The G650 provides the required current source inputs, digital inputs and outputs, and elements to perform breaker failure functions for a three pole tripping scheme. The function can be initiated and blocked internally and/or externally via input contacts or communications.

Overcurrent Protection

Instantaneous and Time Overcurrent functions are available for phase, neutral, ground, sensitive ground, and negative sequence currents. A variety of time curves are provided including IEC, IEEE/ANSI, IAC, I2t, definite time, rectifier curve, and FlexCurve user curves. The phase Time Overcurrent elements have a voltage-restrained feature that can be enabled to allow for easy coordination with other equipment.

Sensitive ground current

The Sensitive Ground IOC (50SG) and Sensitive Ground TOC (51SG) are available in enhanced option can be used as 95% ground stator protection in generators grounded to a resistor.

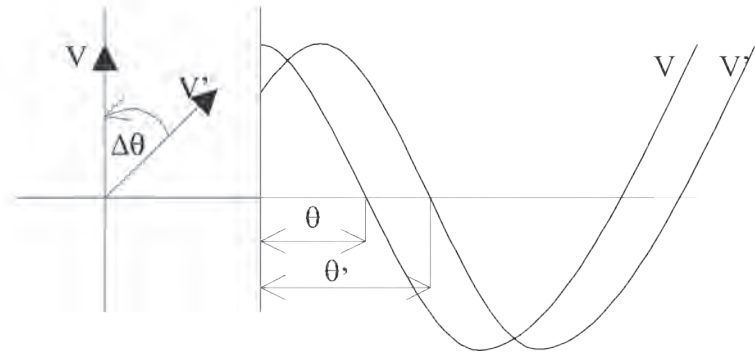

A Loss of Mains condition is detected by means of angle displacement between one Voltage cycle and the previous one.

Generator Current Unbalance

The negative sequence components of unbalance currents cause second harmonic currents to flow in the rotor that can lead to undetected overheating and consequently severe machine damage. The G650 meets ANSI standards to minimize risk of heat damage caused by unbalance in the generator.

The G650 can be set either with a definite time (up to thousands) or with a $I2t=K$ curve model where K is a value between 1 to 100.

Generator Thermal Model

The Generator Thermal Model function protects the generator from overheating as well as overloading. This element includes an overvaluing of the effect of the negative sequence $I2$ component in order to protect the generator from the effects caused by slight system unbalanced currents, such as the ones produced by load unbalance.

Synchronism Check

The synchronism check element is typically used at locations where the two parts of the system are interconnected through at least one other point in the system, which are to be joined by the closure of a circuit breaker. The G650 provides the required voltage source inputs, digital inputs and outputs, and elements to monitor differences in voltage magnitudes, phase angles, and frequencies to perform synchronism check across a circuit breaker. The G650 can be used to carry out full independent control over the associated breaker. When

used in conjunction with an automated system, use the G650 to aid the restoration process with synchronism check feature, as an independent check of the automatic synchronizer.

VT Fuse Failure

The VT fuse failure scheme that is available in the enhanced option, will detect a fuse failure condition through monitoring of the positive and negative sequence voltage and current.

Automation

The control functions of the G650 include a full-featured virtual PLC with an optional graphical HMI display. The combination of both tools allow the user to set the G650 for total breaker control, which include real-time monitoring of breakers and auxiliary disconnecting devices, with open and close commands supervised by programmable interlocking functions.

Programmable Logic

The programmable logic engine in the G650 allows for creating customized control schemes to automatically control the interconnections between the generator and the transmission system. The programmable logic interface meets the IEC 61131-3 Functional Block Diagram industry standard method of programming logical controllers and contains all of the Boolean logic operators required to carry out most distributed generation automation applications.

Programmable Control Logic

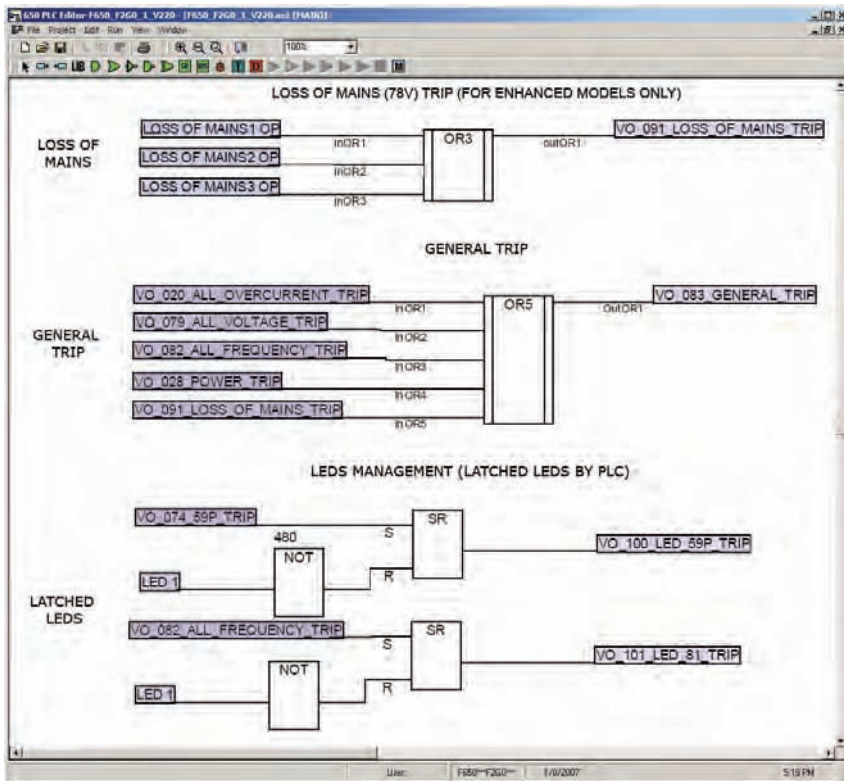

The G650 programmable control logic allows for the creation of customized distributed generator protection schemes and applications.

Scalable Hardware

The G650 is available with up to 64 programmable digital inputs, up to 16 analog inputs and up to 16 digital outputs. Using the additional CIO module that is available, the digital inputs, analog inputs and digital outputs available are increased to 128, 32, and 32 respectively. All digital inputs may be filtered with a separate debounce time to tailor individual requirements. More over, programmable threshold allows the use of different voltage levels (20 to 230 VDC) for each input.

Multiple Setting Groups

Three separate setting groups for protection functions may be stored in the G650. The G650 includes three units for each protection function, all of which can be active simultaneously in a single group, or be grouped in three different tables. An easy to use programmable mechanism is provided to instantly switch the active settings. This switching may be done internally and/or externally via contact inputs or communications or combinations of the above.

Monitoring and Metering

The G650 includes high accuracy metering and recording for all AC signals. Voltage, current, and power metering are built into the relay as a standard feature.

Diagnostics features such as oscillography, and event recording, combined with EnerVista™ software tools, significantly reduce troubleshooting time and simplify report generation in the event of a system fault.

Basic Metering Functions

The G650 provides the following metering values.

- Current: Ia, Ib, Ic, In, Ig, Isg
- Phase-to-phase and phase-to-ground voltage values for bus and line: Van, Vbn, Vcn, Vab, Vbc, Vca, Vx, Vn, Vg
- Active power (per phase and total): Wa, Wb, Wc, W.
- Reactive power (per phase and total): VARa, VARb, VARc, VAR.

- Power factor (per phase and total)
- System Frequency and Frequency Decay Rate

These signals are available for local display, and accessible remotely using communications.

Oscillography

Up to 20 simultaneous Oscillography records can be recorded to monitor up to 9 fixed analog variables (IA, IB, IC, IG, IS,VI, VII, VIII and VX) and any physical I/O point or internal digital operand (up to 16 configurable channels). The waveform traces and digital states provide a visual display of power system and relay operational data captured during specified triggered events. Sampling rates of up to 3600 Hz can be recorded and the capacity of each record will depend on the configuration of Oscillography function.

Event Recorder

Capture the last 479 events, with 1 ms resolution time, to provide SOE recorder functionality. Consolidate the event records from multiple devices using EnerVista software tools and use the IRIG-B time synchronization feature to synchronize all events across a system of relays for even more accurate analysis and troubleshooting.

These records are stored in non-volatile memory. Therefore, there is no need for internal battery monitoring or maintenance.

Trip Circuit Monitoring

The G650 offers as an option two complete supervision circuits for monitoring breaker trip and closing coils circuits. These supervision inputs monitor both the battery voltage level and the continuity of the trip and closing circuits by applying current through those circuits and checking that it flows properly.

Communications

The G650 supports a wide range of communication mediums and protocols compatible with new and existing communication infrastructures.

The G650 includes a maximum of three independent communication ports: COM1, COM2 and COM3, with many physical choices through the use of two removable plug and play boards.

COM1 and COM2 support Modbus® RTU, and serial DNP 3.0. They are located in the first plug and play board, with three different media choices: RS-485, and plastic or glass fiber optic. In addition, COM2 is accessible from the faceplate of the relay through opto-isolated RS232.

COM3 supports ModBus TCP/IP and DNP 3.0 over Ethernet cable (10/100 Base TX) and fiber optic (100 Base FX). The Ethernet port is located in the second plug-and-play board with the options available shown in the table above.

User Interfaces

Keypad & Display

There are two displays available, one with text display (4x20 characters), and one optional large graphic display (16x40 characters) with fluorescent backlit for a better visibility under all conditions.

Monitoring, metering and alarming panel screens can be produced just by clicking and dragging symbols from a complete library of symbols.

LED Indicators

Up to 15 programmable LEDs green, yellow and red, with tags tailored to the application. Five additional large keys, all of them configurable, help automating frequently performed control functions (such as breaker open, close, recloser lockout).

Shuttle

An easy to use "shuttle" type control plus an escape key makes the G650 extremely easy to use, similar to mouse navigation in a PC or a shuttle control in a domestic VCR.

EnerVista™ Software

The EnerVista™ Suite is an industry-leading set of software programs that simplifies every aspect of using the G650 relay. The EnerVista suite provides all the tools to monitor the status of your the protected asset, maintain the relay, and integrate information measured by the G650 into DCS or SCADA monitoring systems. Convenient COMTRADE and Sequence of Events viewers are an integral part of the G650 Setup software included with every relay, to carry out postmortem event analysis to ensure proper protection system operation.

EnerVista™ Launchpad

EnerVista™ Launchpad is a powerful software package that provides users with all of the setup and support tools needed for configuring and maintaining GE Multilin products. The setup software within Launchpad allows configuring devices in real-time by communicating using serial, Ethernet, or modem connections, or offline by creating setting files to be sent to devices at a later time.

Included in Launchpad is a document archiving and management system that ensures critical documentation is up-to-date and available when needed. Documents made available include:

- Manuals
- Application Notes
- Guideform Specifications
- Brochures
- Wiring Diagrams
- FAQs
- Service Bulletins

Viewpoint Monitoring

Viewpoint Monitoring is a simple-to-use and full-featured monitoring and data recording software package for small systems. Viewpoint Monitoring provides a complete HMI package with the following functionality:

- Plug-&-Play Device Monitoring
- System Single-Line Monitoring & Control
- Annunciator Alarm Screens
- Trending Reports
- Automatic Event Retrieval
- Automatic Waveform Retrieval

EnerVista™ Integrator

EnerVista™ Integrator is a toolkit that allows seamless integration of GE Multilin devices into new or existing automation systems. Included in EnerVista Integrator is:

- OPC/DDE Server
- GE Multilin Drivers
- Automatic Event Retrieval
- Automatic Waveform Retrieval

User Interface

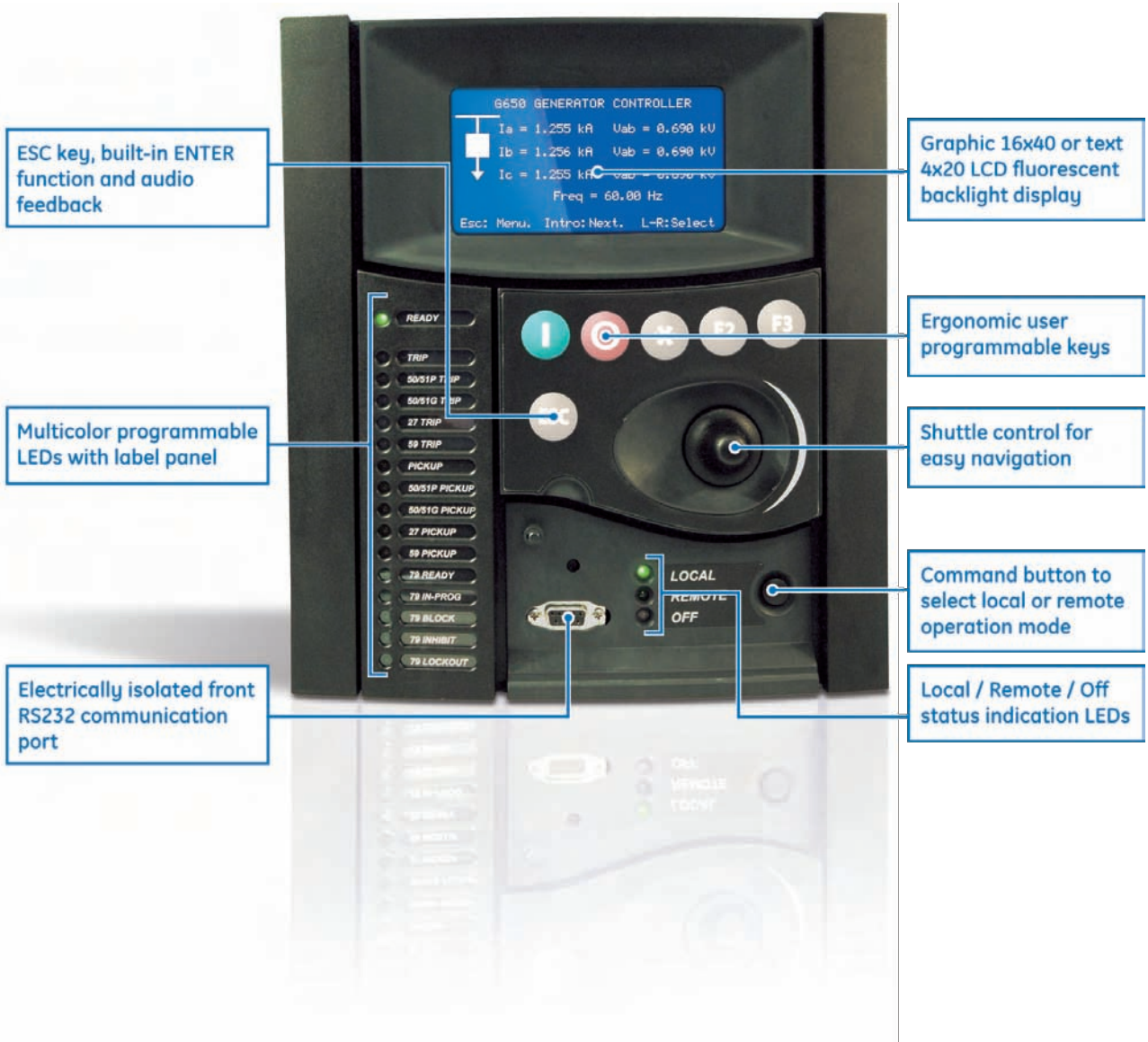

ESC key, built-in ENTER function and audio feedback

Graphic 16x40 or text 4x20 LCD fluorescent backlight display

Multicolor programmable LEDs with label panel

Ergonomic user programmable keys

Shuttle control for easy navigation

Command button to select local or remote operation mode

Electrically isolated front RS232 communication port

Local / Remote / Off status indication LEDs

Typical Wiring

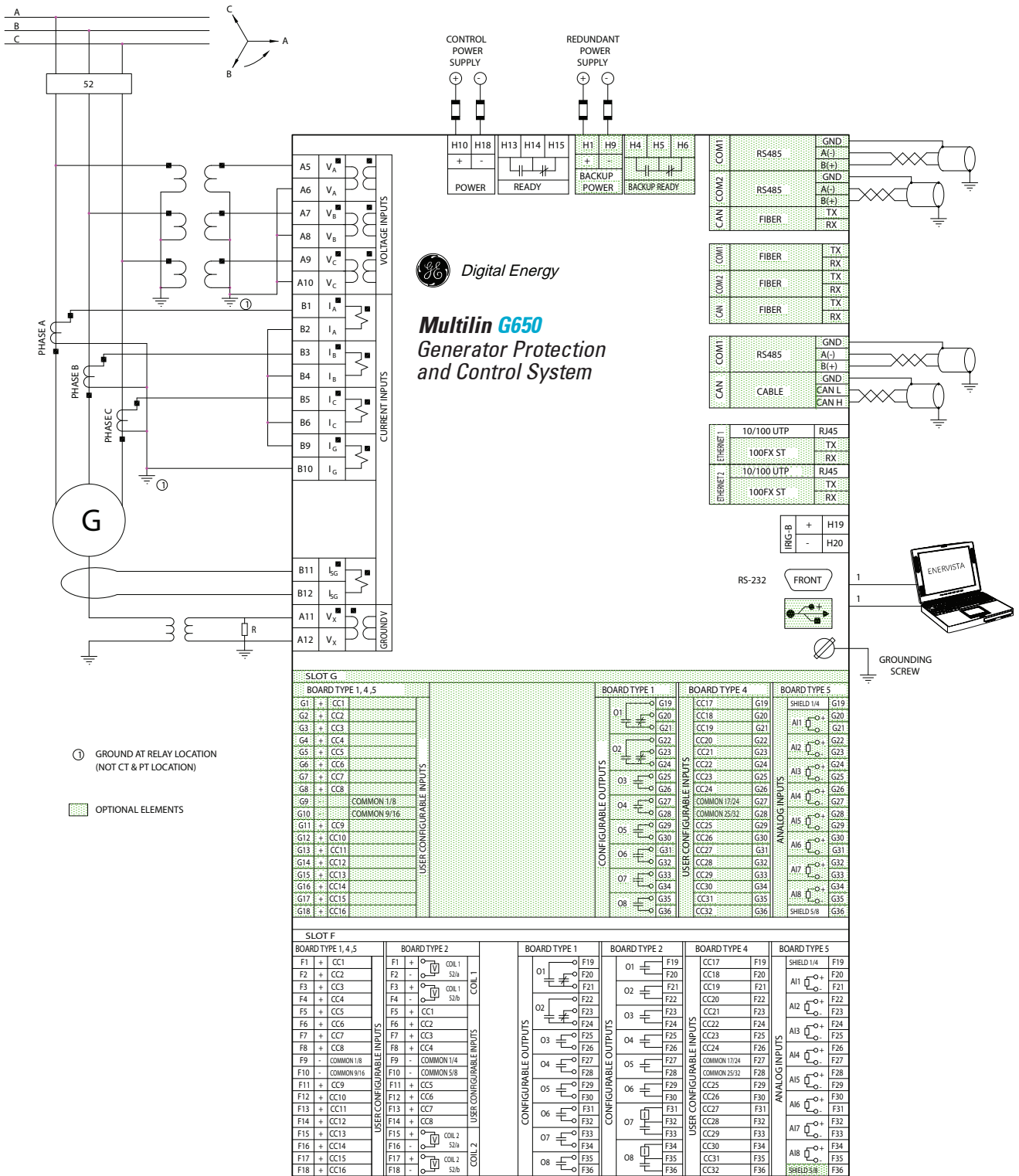

Ordering

To order select the basic model and the desired features from the Selection Guide below:

G650	*	*	*	F	*	G	*	*	*	Description
Display and Functionality Options	B M N E C D									Basic Display and Basic Protection Functionality. Graphical Display with Standard Symbols and Basic Protection Functionality. Graphical Display with IEC Symbols and Basic Protection Functionality. Basic Display and Enhanced Protection Functionality. Graphical Display with Standard Symbols and Enhanced Protection Functionality. Graphical Display with IEC Symbols and Enhanced Protection Functionality.
Rear Serial Communications Board 1		F A P G X Y Z C M								None Redundant RS485 Redundant plastic F.O. Redundant glass F.O. Redundant RS485 + remote fiber CAN bus I/O Redundant plastic F.O. + remote fiber CAN bus I/O Redundant glass F.O. + remote fiber CAN bus I/O Remote cable CAN bus I/O RS485 + Remote cable CAN bus I/O
Rear Ethernet Communications board 2			B C D E							10/100 BaseT 10/100 BaseT + 10/100 Base FX 10/100 BaseT + redundant 10/100 Base FX Redundant 10/100 Base TX
I/O board 1					1 2 4 5					16 digital inputs + 8 outputs 8 digital inputs, 4 circuits for circuit supervision, 6 Outputs + 2 outputs with circuits for trip current supervision (latching) 32 Digital Inputs 16 Digital Inputs + 8 Analog Inputs
I/O board 2						0 1 4 5				None 16 Digital Inputs + 8 Outputs 32 Digital Inputs 16 Digital Inputs + 8 Analog Inputs
Auxiliary Voltage							LO HI LOR HIR			24-48 Vdc (range 19.2 - 57.6) 110-250 Vdc (range 88-300) 120-230 Vac (range 88-264) Redundant LO Redundant HI
Environmental Protection								- H		Without Harsh (Chemical) Environment Conformal Coating Harsh (Chemical) Environment Conformal Coating

Accessories for the G650

- Multilink Ethernet Switch ML1600-HI-A2-A2
- Multinet Multinet-FE
- Viewpoint Monitoring VP-1

Visit www.GEMultilin.com/G650 to:



- View Guideform specifications
- Download the instruction manual
- Review applications notes and support documents
- Buy a G650 online
- View the G650 brochure