



Digital Energy
ITI

Instrument Transformer Basic Technical Information and Application



Table of Contents

DEFINITIONS AND FUNCTIONS	3
CONSTRUCTION FEATURES	3
MAGNETIC CIRCUITS	5
RATING AND RATIO	5
CURRENT TRANSFORMER THERMAL RATING FACTOR	6
POTENTIAL TRANSFORMER THERMAL RATING	6
PT OVERVOLTAGE REQUIREMENTS	6
INSULATION/VOLTAGE CLASS	7
POLARITY	7
ACCURACY CLASSIFICATION AND BURDEN	8
METERING ACCURACY	9
RELAY ACCURACY OF A CURRENT TRANSFORMER	9
CONNECTIONS – POTENTIAL TRANSFORMERS	10
CONNECTIONS – CURRENT TRANSFORMERS	10
CONNECTIONS – STANDARD METERING	11

Definitions and Functions

The name instrument transformer is a general classification applied to current and voltage devices used to change currents and voltages from one magnitude to another or to perform an isolating function, that is, to isolate the utilization current or voltage from the supply voltage for safety to both the operator and the end device in use. Instrument transformers are designed specifically for use with electrical equipment falling into the broad category of devices commonly called instruments such as voltmeters, ammeters, wattmeters, watt-hour meters, protection relays, etc.

Figure 1 shows some of the most basic uses for instrument transformers. Voltage transformers are most commonly used to lower the high line voltages down to typically 120 volts on the secondary to be connected to a voltmeter, watt-hour meter, or protection relay. Similarly, current transformers take a high current and reduce it to typically 5 amps on the secondary winding so that it can be used with a watt-hour meter, ammeter, or protection relay.

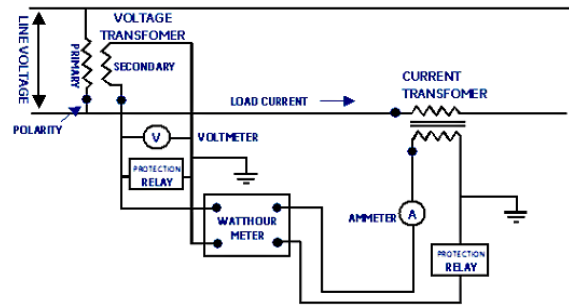

Figure 1 – Common uses of instrument transformers

Construction Features

Potential transformers consist of two separate windings on a common magnetic steel core. One winding consists of fewer turns of heavier wire on the steel core and is called the secondary winding. The other winding consists of a relatively large number of turns of fine wire, wound on top of the secondary, and is called the primary winding.

Current transformers are constructed in various ways. One method is quite similar to that of the potential transformer in that there are two separate windings on a magnetic steel core. But it differs in that the primary winding consists of a few turns of heavy wire capable of carrying the full load current while the secondary winding consist of many turns of smaller wire with a current carrying capacity of between 5/20 amperes, dependent on the design. This is called the wound type due to its wound primary coil.

Another very common type of construction is the so-called “window,” “through” or donut type current transformer in which the core has an opening through which the conductor carrying the primary load current is passed. This primary conductor constitutes the primary winding of the CT (one pass through the “window” represents a one turn primary), and must be large enough in cross section to carry the maximum current of the load.



Window-type



Wound



Bar-type

Construction Features - Indoor vs Outdoor

Another distinguishing feature is the difference between indoor and outdoor construction. The performance characteristics of the two constructions are essentially the same, but the physical appearance and hardware are different. The outdoor unit must be protected for possible contaminated environments while indoor units are protected due to their being mounted in an enclosure of some kind. Thus most outdoor units will have larger spacing between line and ground, which is achieved by the addition of skirts on the design. This provides larger surface creepage distances from the primary

terminals (at line potentials) to the secondary terminals and the base plate (at ground potentials). For outdoor types the hardware must be of the non-corrosive type and the insulation must be of the non-arc-tracking type. One other feature that differentiates the indoor from the outdoor is the orientation of the primary terminals. The indoor types must be compatible for connection to bus type electrical construction as opposed to the outdoor types that are normally on the pole-top installations.



15kV Outdoor CT



15kV Indoor CT

How To Modify The Ratio on a Current Transformer

The secondary consists of a larger number of turns of smaller wire. The number is dependent on the primary to secondary current transformation desired. If a lower current rating than is available is required due to a low load density, this can be achieved by looping the primary cable through the window of the CT. An example would be the need for a 100 ampere to 5 unit when the lowest current rating made by the manufacturer was 200 to 5 amperes. By looping the cable through the window so that the cable passes through the window twice, we can make an effective 100:5 ampere unit out of a 200:5 ampere unit. Smaller increments of current change can be achieved by adding or backing off secondary turns as well as primary turns, i.e., we can make a 110:5 ampere unit out of a standard 200:5 ampere unit by adding 2 primary turns and adding 4 secondary turns. The primary amperes turns must equal

the secondary ampere-turns. Thus 110 amperes X 2 turns is 220 ampere turns on the primary. To equalize this on the secondary of a standard 200:5 ampere unit which has 40 turns (40 X 5 amperes = 200NI), we would have to add 4 secondary turns through the window of the CT thus giving us a total of 44 secondary turns X 5 amperes = 220 ampere turns. Thus we have modified a standard 200:5 ampere CT to be a 110:5 ampere unit by adding 2 external primary turns and 4 external secondary turns to it. Had we chosen to back off the 4 secondary turns instead of adding, we would have had a 90:5 ampere CT. Refer to instruction for using a variable-ratio current transformer.

Magnetic Circuits

Instrument transformers can be simplified with basic magnetic circuits. Figure 2 depicts the most basic magnetic circuit of an ideal instrument transformer. As a current passes through the primary winding it induces a magnetic flux in the steel core. The flux flows through the core and induces a current on the secondary winding proportional to the ratio of turns on the primary to the secondary.

Instrument transformers are not a perfect device and incur losses from resistance and stray inductance of the copper winding and core. The two biggest losses are due to the copper windings that carry the current and the magnetic core that carries the flux. Figure 3 below shows the electric circuit and associated losses of an actual transformer. Figure 4 shows the equivalent circuit for a current transformer.

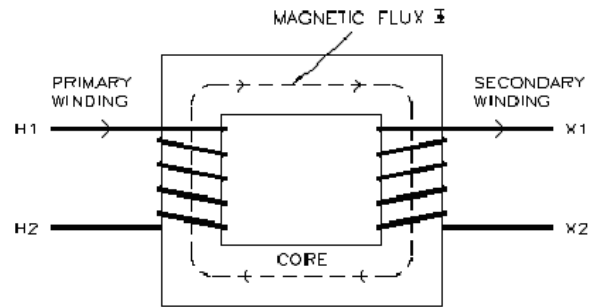

Figure 2 – Basic Magnetic Circuit

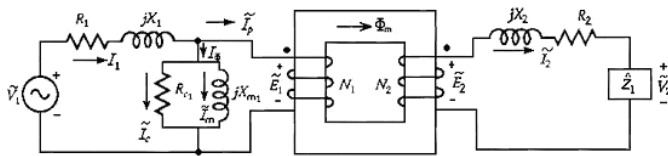
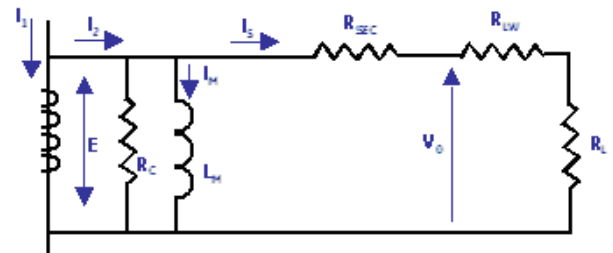

Figure 3 – Non-Ideal Magnetic Circuit



- $I_2 = I_2 + I_m$
- $I_1 =$ Primary Current
- $I_2 =$ Secondary Current for ideal transformer
- $I_2 =$ Secondary Current seen on secondary
- $I_m =$ Magnetization Current
- $E =$ Induced Electromotive Force
- $V_0 =$ Secondary Voltage
- $L_m =$ Magnetizing Inductance
- $R_c =$ Core Loss
- $R_{SEC} =$ Resistance of secondary
- $R_{LW} =$ Resistance of leadwire
- $R_L =$ Resistance of load

Figure 4 – Equivalent Circuit

Rating and Ratio

The rating of an instrument transformer is expressed by two groups of numbers representing the nominal current or voltage which may be applied to its primary winding and the current or voltage which would then be induced in its secondary winding. For example, the designation 480:120 volt expresses the rating of the potential transformer. This means that when 480 volts is applied to the primary winding, 120 volts will be induced on the secondary. Likewise a designation of 400:5 amperes expresses the rating of a current transformer and means that when 400 amperes flow through the primary, 5 amperes will flow through the secondary.

Industry standards have established 120 volts as the secondary rating of potential transformers having primary ratings up to 24,000

volts and 115 volts as the secondary rating of PT's having ratings above 24,000 volts. Similarly, industry standards have established 5 amperes as the secondary rating of current transformers.

The ratio of an instrument transformer is the relationship of its primary rating to its secondary rating. For example, the potential transformer mentioned above having a rating of 480:120 volts will have a ratio of 4:1 and the current transformer having a rating of 400:5 amperes will have a ratio of 80:1.

Current Transformer Thermal Rating Factor

Rating factor (RF) is a term, which applies to a current transformer. In its application to a current transformer, it is the number representing the amount by which the primary load current may be increased over its nameplate rating without exceeding the allowable temperature rise. In other words, it is a designation of the transformer’s overload capability. In order to be completely meaningful, the ambient temperature at which the rating factor applies should be stated. The standard ambient reference levels are at 30°C or 55°C. In the manufacturer’s literature, a typical statement would be: RF 2.0 at 30°C ambient with RF 1.5 at 55°C ambient. These statements mean that in a 30°C ambient, the CT will safely carry on a continuous basis 2 times the nameplate rating and at 55°C ambient, it will carry 1.5 times the nameplate rating.

It is very important that the ambient temperature be considered when applying CT’s above the rating. Typical rating factors of CT’s are 1.0, 1.25, 1.33, 1.5, 2.0, 3.0, and 4.0.

Many times the manufacturer will only list the CT rating factor at 30°C ambient (room temperature). If you wish to know what the rating factor is at some other ambient temperature, you will have to convert the value by use of a rather simple proportional equation. Following is a typical example:

The manufacturer states his 400:5 ampere CT has a rating factor of 4.0 at a 30°C ambient and you wish to know how much you must derate it when it is put in an enclosure where the highest ambient temperature might be 55°C.

The basic formula for a 55°C rise CT is:

$$\frac{(\text{New RF at New AMB})^2}{(\text{Stated RF at } 30^\circ\text{C})^2} = \frac{85 - \text{New AMB } ^\circ\text{C}}{55^\circ\text{C}}$$

And for our particular example:

$$\frac{(X)^2}{(4.0)^2} = \frac{30}{55}$$

$$X^2 = 8.73$$

$$X = \text{RF @ } 55^\circ\text{C} = 2.95$$

Thus where the 400 ampere unit could carry (400 X 4.0) 1600 amperes primary at 30°C ambient without exceeding the manufacturer’s recommended transformer thermal rating, it can safely carry only 2.95 x 400 at 55°C. The IEEE standard C57.13 provides a graph depicting the change in thermal rating to ambient temperature as well.

Potential Transformer Thermal Rating

Potential transformers have a thermal rating rather than a rating factor as with the CT and it designates the maximum volt-ampere

burden, which may be connected to its secondary at specified ambient temperatures of either 30 or 55°C.

Potential Transformer Overvoltage Requirements

The IEEE standards allow two levels of operation. One is a continuous operation level and one is for emergency conditions. A potential transformer must be capable of operating at 110% above rating voltage continuously provided the secondary burden in volt amperes at this voltage does not exceed the thermal rating. The emergency rating of potential transformers is defined at one minute of operation, thus enough time for protective equipment to operate.

Voltage Transformer Ratings and Characteristics			
GROUP	BUSHINGS	RATING	RVF
1	2	L-G	1.25/8hr
2	2	L-L	-
3	1	L-G	(25-161kV, 1.74/1min) (230-750kV, 1.40/1min)
4A	1	L-G	1.25/8hr
4B	1	L-L	-
5	1	L-G	1.40/1min

IEEE C57.13-2008 defines five distinct groups of voltage transformers and provides ratings and characteristics of each grouping. This table summarizes each grouping.

Insulation/Voltage Class

The insulation class indicates the magnitude of voltage, which an instrument transformer can safely withstand between its primary and secondary winding and between its primary or secondary winding and ground (core, case or tank) without a breakdown in the insulation. Industry standards have established insulation classes ranging from 600 volts up through 545 KV. System voltages presently extend up to 765 KV with 1100 and 1500 KV being investigated for future transmission expansions. Industry recommendations

are that the insulation class of an instrument transformer should be at least equal to the maximum line-to-line voltage existing on the system at the point of connection. For example, the insulation class of a potential transformer used on a 7200/12470 volt system should be 15 KV even though the PT has a primary rating of 7200 volts and is connected phase-to-ground. Similarly, any current transformer used on a 7200/12470Y volt system should be of the 15 KV insulation class. Under fault conditions these units could be subjected to line-to-line voltage.

Polarity

In the application of instrument transformers it is necessary to understand the meaning of polarity and to observe certain rules when connecting watt-hour meters, relays, etc. If you will accept the fact, without proof, that the flow of current in the secondary winding is in a direction opposite to in the primary winding, that is, 180° out of phase with it, it will be relatively simple to understand the meaning of polarity. At any instant, when the current is flowing into one of the primary terminals it will be flowing out of one of the secondary terminals.

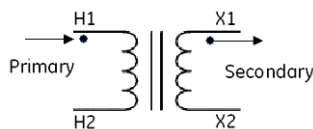

The polarity of a transformer therefore is simply an identification of the primary terminal and the secondary terminal, which satisfies the previously stated conditions. All instrument transformers, whether current or potential will have polarity marks associated with at least one primary terminal and one secondary terminal. These markings usually appear as white dots or letter and number combinations. When number and letter combinations are used IEEE refers to H1 as the primary terminal marking and to X1 for the secondary polarity mark.

In applications which depend on the interaction of two currents, such as a watt-hour meter or protective relay, it is essential that the polarity of both current and potential transformers be known and that definite relationships are maintained.

While all instrument transformers should be clearly marked as to their polarity, it is sometimes necessary to verify existing markings or to determine the polarity of an old or unmarked transformer. One simple method of determining polarity on a potential transformer is to connect a suitable DC permanent magnet voltmeter, preferably one with a 150 volt range, across the high voltage terminals, with the marked primary terminal of the transformer connected to

the plus (+) terminal of the voltmeter. Then connect a battery and connect the plus (+) terminal of the battery to the marked secondary terminal. Make an instantaneous contact between the negative (-) terminal of the battery and the unmarked or (X2) secondary terminal of the transformer. A deflection or "kick" will be indicated on the voltmeter. If the initial "kick" (the one resulting from making, not breaking the circuit) is in an upscale direction, the potential terminals are marked correctly.

Similarly, a polarity check may be made on a current transformer. Connect a DC permanent magnet ammeter of 5 ampere capacity or less (depending on the transformer ratio) across the current transformer secondary. Connect the plus connect a battery in series and connect the negative (-) terminal of the battery to the unmarked of (H2) marked terminal of the transformer, make an instantaneous contact between the marked or (H1) primary terminal of the transformer and the plus (+) terminal of the battery. If the initial kick (the one resulting from making not breaking the circuit) is upscale, the current transformer terminals are marked correctly.

Precautions should be taken when making this test on current transformers to prevent core magnetization from occurring due to the direct current. Window or bar type units with low current ratings (400 ampere and down) are particularly susceptible to this residual magnetism. It is a best practice to demagnetize the CT after using DC. This can be accomplished by connecting at least 50 ohms variable across the secondary terminals and bring the primary current up to full load. Reduce the series resistance until it reaches zero without opening the secondary circuit. For best results, gradually reduce the primary circuit to zero before disconnecting the resistance circuit.

Accuracy Classification and Burden

The IEEE has established standardized methods of classifying instrument transformers as to accuracy and burden. An accuracy classification for an instrument transformer includes the standard burden as well as the maximum percent error limits for line power factors between 100% and 60% lagging. A typical CT classification might be 0.3 B0.5 where the 0.3 is the percent allowable error and the B0.5 is the secondary burden in ohms impedance. The accuracy is dependent on the burden.

It is extremely important at this point to have a very clear understanding of the term "burden" as it is used in connection with instrument transformer accuracy classifications. The term "burden" has been adopted to distinguish it from "load" which is generally associated with the primary, especially with current transformers. For example, the load rating of a current transformer indicates the load (in current) which may be applied to its primary, while the burden rating indicates the amount of resistance (in ohms) and inductance (in milli-henries) which may be connected to its secondary without causing a metering error greater than specified by its accuracy classification.

The types of meters and relays and the size and length of wire connected to the secondary side of the instrument transformer make up its burden.

These values can be calculated by converting each device into terms of voltamperes and power factor, and doing a vector analysis to determine what the total effective burden on the transformer is. A more practical way is to obtain from the manufacturer the burden of each device in terms of watts and vars and calculate the total the total effective burden on the instrument transformer. A typical example might be as follow:

A utility is trying to determine what accuracy and burden classification CT to purchase for a particular metering application. The various meters and instruments to be used are known and the distance and size of wire to be used between the CT and the meters are known

Standard ANSI values of accuracy burdens for CT's and PT's are listed below, as well as in the IEEE standards manual, C57.13.

Devices	Burden at 5 Amperes 60 Hz	
	Watts	Vars
IB-10 (Rotating Std 5A)	0.80	0.80
I-50 Watthour Meter	0.31	0.42
P-3 Ammeter (5A)	1.50	0.90
100 circuit feet of #12 AWG Cu Wire	4.00	0.00
	6.61	2.12

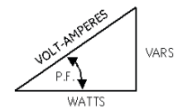

$$VA = \sqrt{[(WATTS)^2 + (VARS)^2]}$$

$$VA = \sqrt{[(6.61)^2 + (2.12)^2]} = 6.94 \text{ VOLT-AMPERES}$$

$$P.F. (\text{Power Factor}) = \cos \tan^{-1} (VARS/WATTS)$$

$$P.F. = 0.321 \cos (72.2^\circ) = .95$$

CONCLUSION: Since 6.94 VA at .95 P.F. exceed B0.2 burden (which is 5.0 VA at .9 P.F.) the utility must use a transformer that has a 0.3B0.5 classification (or 12.5 VA at .9 P.F. capability).

STANDARD CT BURDENS						
Application	Burden Designation	Resistance (Ohms)	Inductance (mH)	Impedance (Ohms)	VA @ 5 Amps	Power Factor
Metering	B0.1	0.09	0.116	0.1	2.5	0.9
	B0.2	0.18	0.232	0.2	5	0.9
	B0.5	10.45	0.58	0.5	12.5	0.9
	B0.9	0.81	1.04	0.9	22.5	0.9
	B1.8	1.62	2.08	1.8	45	0.9
Relaying	B-1	0.5	2.3	1	25	0.5
	B-2	1	4.6	2	50	0.5
	B-4	2	9.2	4	100	0.5
	B-8	4	18.4	8	200	0.5

*Applicable only at 60Hz and a 5 Amp secondary. For secondary current other than 5 Amps, multiply the resistance and inductance in the table by (5/ampere rating)², the other variables remain the same as in the chart.

STANDARD VT BURDENS					
Burden Designation	Resistance (Ohms)	Inductance (mH)	Impedance (Ohms)	VA @ 5 Amps	Power Factor
W	115.2	3.04	1152	12.5	0.1
X	403.2	1.09	576	25	0.7
M	82.3	1.07	411	35	0.2
Y	163.2	0.268	192	75	0.85
Z	61.2	0.101	72	200	0.85
ZZ	30.6	0.0503	36	400	0.85

*Applicable only at 60Hz and a 120V secondary

Relay Class & Associated Burdens	
Secondary terminal Voltage	Standard Burden
C10	B-0.1
C20	B-0.2
C50	B-0.5
C100	B-1
C200	B-2
C400	B-4
C800	B-8

Metering Accuracy

There are two sources of error in instrument transformers, namely ratio error and phase angle error. In a given transformer, the metering error is the combination of the two separate errors. This combination is called Transformer Correction Factor (TCF), IEEE has established accuracy classes for both current and potential transformers. The limit of permissible error in a potential transformer for a given accuracy class remains constant over a range of voltage from 10% below to 10% above rated voltage. In the figure to the right is a standard test card provided by the manufacturer showing the performance of the CT at 10% and 100% of rated current.

Type: JAB-0C		Catalog No.: 750X136208	
Ratio: 800:5		Serial No.: 62869728	
Secondary Burden	Secondary Amps	Ratio Correction Factor	Phase Angle (minutes)
B0.5	5	1.0015	4.4
	0.5	1.0024	9.7

Date: 7/15/2009
Tested By: AB

Instrument Transformer
IEEE certifies that the instrument transformer has been tested and found to meet its performance requirements in accordance with its standard for the applicable IEEE C57.13-2008 insulation level and accuracy classes. The data herein is the property of the National Institute of Standards and Technology.

The limit of permissible error in a current transformer accuracy class has one value at 100% rated current and allows twice that amount of error at 10% rated current. Typically 0.3% error is acceptable for watt-hour metering, 0.6% to 1.2% error for indicating instruments. The figure to the right shows the performance limits of a standard metering 0.3% accuracy CT with a rating factor of 4.0.

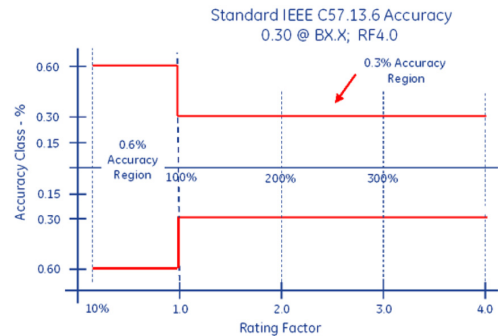

High Accuracy Instrument Transformers

Two new accuracy classes have been developed by IEEE C57.13.6 to accommodate the shift towards electronic relays and meters from the traditional induction devices. Consequently, manufacturers have begun to improve accuracy of instrument transformers to take advantage of the lower impedance of the devices. Included in the new high accuracy standard are new testing points and burdens to verify performance. New burdens of E,04, (1.0 Volt-Ampere at 5Amp, unity power factor), E0,2, (5.0 Volt-Ampere at 5Amp, unity power factor), and low current test point of 5% versus the traditional 10% rated current, are now required.

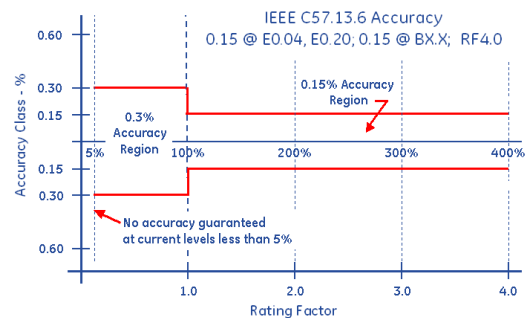

0.15 Accuracy Instrument Transformers

Current transformers must maintain 0.15% accuracy from rated current through rating factor at rated burden. At 5% rated current through 100%, the current transformer must maintain 0.3% accuracy. No accuracy is guaranteed at levels below 5%. Voltage transformers are 0.15% accuracy from 90%-110% of rated voltage.

The associated figure depicts the performance with accuracy on the vertical axis and rating factor on the horizontal axis.

0.15S Accuracy Instrument Transformers

Current transformers must maintain 0.15% accuracy from 5% rated current through rating factor at rated burden. No accuracy is guaranteed at levels below 5%. Voltage transformers are 0.15% accuracy from 90%-110% of rated voltage.

Relay Accuracy of a Current Transformer

Current transformers that are used to operate relays for control and system protection must have certain accuracy during over-current conditions. The transformer must be able to not only withstand the high currents involved, but must also transform current to a lower value suitable for application to the relay terminals, and do this with a reasonable accuracy. A typical relay accuracy classification might be C200 or T200.

The “C” stands for calculated and means that the window and bar type units which have a fully distributed secondary winding on a low leakage flux core thus leading itself to calculated values. The “T” stands for tested because wound type units do not have fully distributed windings, they must be tested because the leakage reactance is not predictable. The last number is the secondary voltage that can be developed at the secondary terminals without saturation.

Thus the meaning of the relay classification!

C200 would be (10% accuracy inferred at 20 X normal current X secondary impedance

OR

$$V = IR$$

$$200 \text{ volt} = (20 \times 5 \text{ amps}) \times B2.0 \text{ ohms}$$

Thus, this CT would have an error of no larger than 10% at 20 times normal secondary current with a secondary burden of 2.0 ohms.

Manufacturers will often offer a graph of the excitation performance of a particular CT. The graph allows the end user to determine the performance of the CT over the entire range of secondary current and ensure that the CT will function as required. The figure to the right shows a typical excitation curve of a relay class CT.

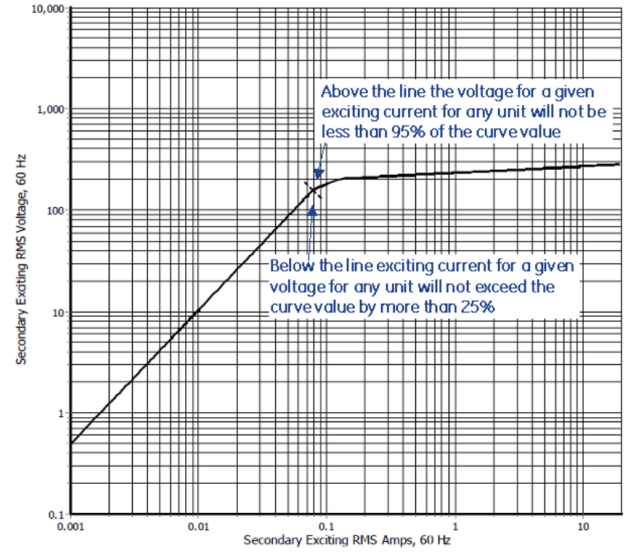

Connections - Potential Transformers

Potential transformers are normally connected across two lines of the circuit in which the voltage is to be measured. Normally they will be connected L-L (line-to-line) or L-G (line-to-ground). A typical connection is as follows:

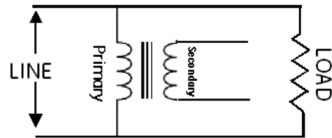

When a phase relationship of "direction of flow" is of no consequence, such as in a voltmeter which operates only according to the magnitude of the voltage, there is no need to observe the polarity of the transformer. However, in watt-hour meter applications, polarity must always be observed.

Most potential transformers have a single winding secondary as previously shown, however, they may have tapped secondary windings, or dual secondary windings.

Connections - Current Transformers

CT's with wound primaries always have their primary windings connected in series with the line and the load and their secondary windings connected to the burden (the watt-hour meter current coil) as show below:

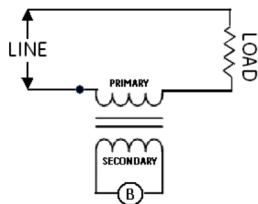

Current transformers having a center tapped secondary are referred to as a dual ratio CT. They are used in applications where

it is necessary to have available two ratios of primary to secondary current from the same secondary winding of the CT. This may be accomplished by adding a tap in the secondary winding to get a second ratio. The ratio obtained by the tap is usually one-half the ratio obtained by the full secondary winding. A schematic example is shown below. With 200 amperes flowing in the primary,

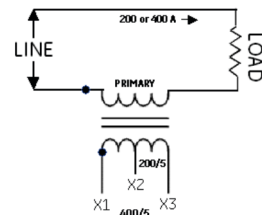

a connection X2 – X3 will produce 5 amperes out of the secondary. Then as the load grows to 400 amperes, the secondary circuit will be reconnected to X1 – X3 to produce 5 amperes in the secondary. It is not recommended to reconnect while the unit is energized, the secondary terminals must be short circuited so as not to induce high voltage in the secondary circuit when the circuit is opened to make the connection. Voltage from a few hundred volts to several thousand volts, dependent on the design, can be developed in the secondary circuit when it is open circuited with current flowing in the primary winding. On a dual ratio tapped secondary CT, both the full winding and the tapped winding cannot be operated simultaneously. The unused terminal must be left open to avoid short circuiting a portion of the secondary winding.

Another design of CT quite commonly used is the double secondary CT. In this configuration the CT has two cores, two secondary windings and one common primary winding. Its application would be for using one CT to both meter and relay a common circuit where the metering circuit must be isolated from the relaying circuit.

A schematic of this would like this:

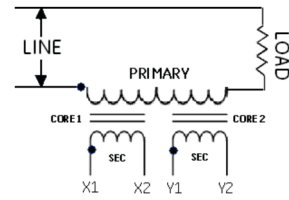

In this design, if both the circuits are not going to be used simultaneously, then the unused circuit must be short circuited while the other is energized or you will develop an induced high voltage on the open circuited unused CT.

Connections - Standard Metering

Typical current transformer connections on three common circuits will illustrate the principles involved in making CT installations.

THE 4 WIRE, "Y" 3 PHASE CIRCUIT

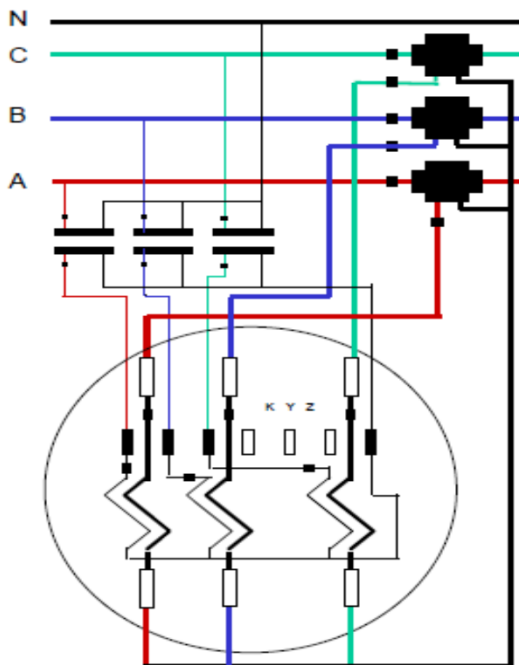

THE 4 WIRE, 3 PHASE CIRCUIT (DELTA CONNECTION)

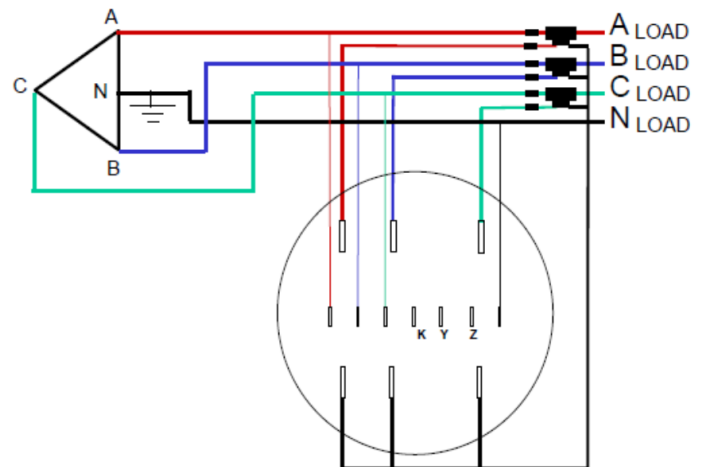

Typical Examples:

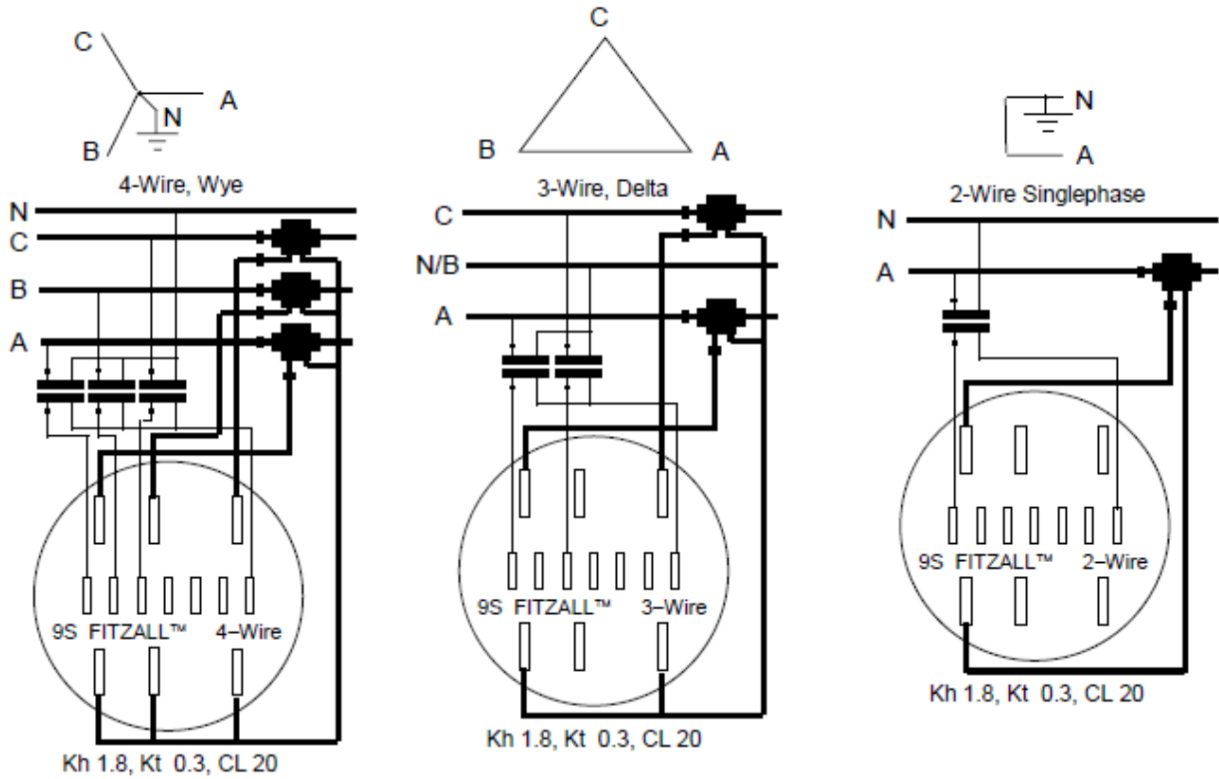

Digital Energy
ITI

GE Digital Energy - ITI
1907 Calumet Street
Clearwater, Florida, USA, 33765
www.GEDigitalEnergy.com