

## M Family Digital Machine Protection Relay



*Three-phase protection  
for electrical machines.*

### Features and Benefits

- Advanced 16-bit microprocessor
- Configurable logic, curves, digital I/Os and LEDs
- Flash memory for field upgrades
- Two settings groups
- Drawout case for easy maintenance
- AC/DC power supply
- Access via front panel keypad or communication links
- Compatible with M Family systems in half or full 19" racks

### Applications

- Protection and control for generators, motors, and transformers

**NEW** ■ enerVista.com compatible (see page 275)

### Protection and Control

- Thermal image protection
- Unbalance
- Overcurrent and undercurrent
- Monitoring and metering
- Analog/digital oscillography
- 24 event recording
- Restricted ground fault

### User Interfaces

- M+PC software for setting and monitoring
- Front RS232 and rear RS485 ports using ModBus® RTU protocol up to 19,200 bps



## Protection

The MIG Digital Machine Protection Relay is designed specifically for small generators and motors. As part of the M Family, the MIG provides superior protection which includes:

### Thermal Image Unit

The thermal image algorithm protects the machine from negative sequence components that can cause overheating in the stator and rotor, as well as overload.

### Unbalance

Protection against rotor damage is provided through definite time or time curve models, to minimize heating caused by the negative sequence current generated by supply voltage unbalance.

### Three-Phase TOC

This protection can be set from 0.1 to 2.4 times  $I_n$ . Four separate ANSI or IEC TOC curves can be selected including definite time, normal inverse, very inverse, and extremely inverse. Additionally, a user configurable curve is available. Different time multipliers may be set for each curve, optimizing curve selection for coordination with fuses, machines, motors, transformers, or other equipment.

ANSI	IEC/BS142
normal inverse	IEC A
very inverse	IEC B
extremely inverse	IEC C
definite time	definite time

### Phase IOC Units

Adjustable phase IOC allows the pickup setpoint to be set from 0.1 to 30 times  $I_n$  and a time delay from 0 to 100 seconds.

### Ground TOC

This feature has the same curve selection choices and settings as the phase TOC unit. The ground signal is normally derived as the residual sum of the three-phase CTs eliminating the need for

an additional ground sensor. Alternatively, for more sensitive detection, an additional core balance (zero sequence) ground sensor encircling the three-phase conductors can be used.

### Ground IOC Units

This protection has the same settings and features as the phase IOC unit.

### Undercurrent

This function is used in motor applications to detect a decrease in machine current caused by load decrease. The unit can be set as an alarm or trip.

### Starts/Hour and Time To Restart

This feature counts the number of machine starts during a time window to ensure they do not

## Functional Block Diagrams

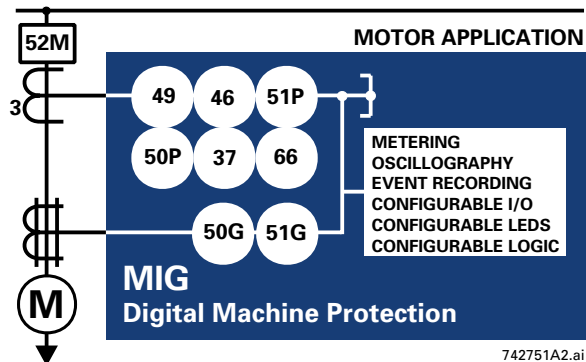
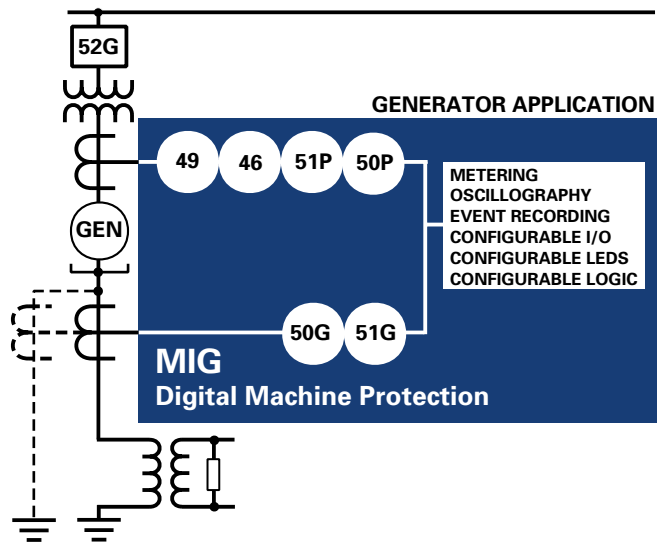

742751A2.ai

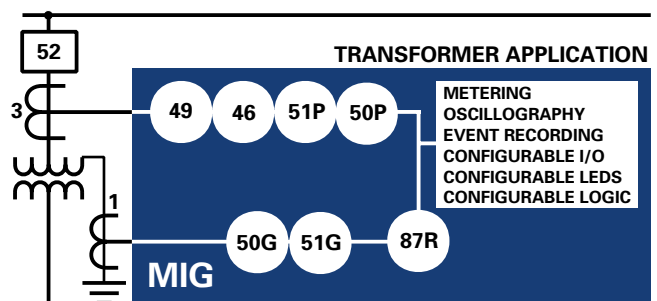

742752A2.ai

exceed the number programmed by the user. If the number is exceeded, the unit blocks any new attempts and keeps the trip contact closed during the restart block time.

**Locked Rotor**

The MIG provides protection during extra-long start-ups where excessive overcurrent conditions can damage rotors. This protection is critical for power applications where the motor drives the generator into service.

**Restricted Ground Fault**

Restricted Ground Fault (RGF) protection provides sensitive ground fault detection for low magnitude fault currents that may not be detected by other protection functions. This protection is often applied to machines and transformers having impedance grounded wye windings.

**Inputs and Outputs**

The factory configuration of MIG inputs and outputs can be easily modified using M+PC software. Two digital inputs and six relay outputs are provided, four of them programmable. These configurable outputs can be assigned either to a set of pre-configured values, or to an OR/NOT combination of the same values.

**MIG Guideform Specifications**

For an electronic version of the MIG guideform specifications, please visit: [www.GEindustrial.com/Multilin/specs](http://www.GEindustrial.com/Multilin/specs), fax your request to 905-201-2098 or email to [literature.multilin@indsys.ge.com](mailto:literature.multilin@indsys.ge.com).



**Typical Wiring**

**Note:** Only for reference. For particular connections for any MIG model, please refer to its external connections drawing.

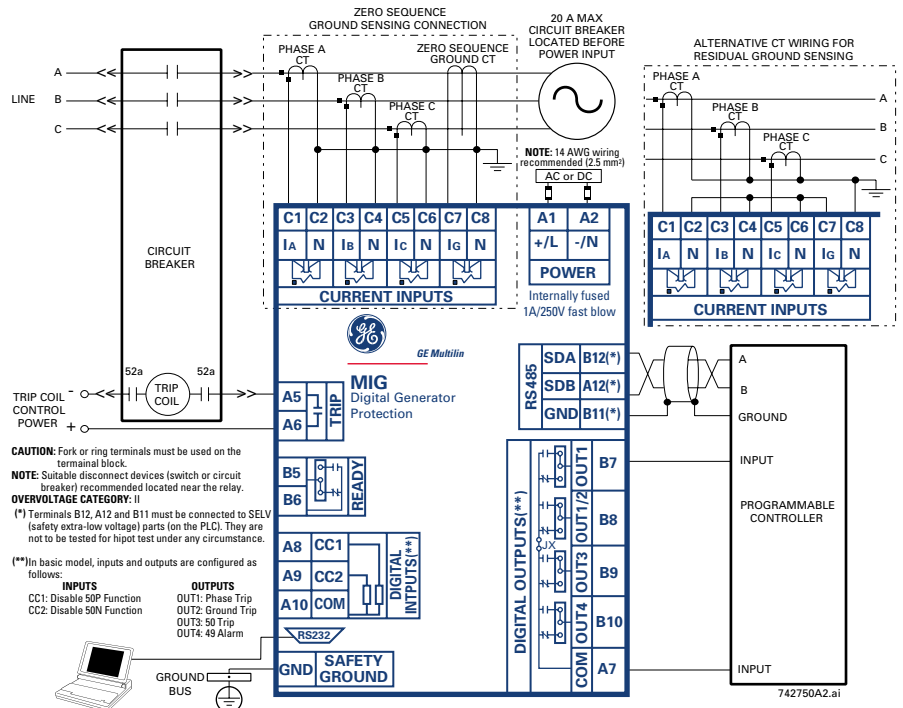

**Ordering**

MIG	P	*	*	*	E	O	00	*	00	*
MIG	P	A	1	5	N	F	H	C	S	
										Digital machine protection relay
										Three-phase + ground relay
										ANSI curves
										IEC curves
										Phase CT I <sub>n</sub> = 1A (pickup range: 0.1 – 2.4 A)
										Phase CT I <sub>n</sub> = 5A (pickup range: 0.5 – 12 A)
										Ground CT I <sub>n</sub> = 1A (pickup range: 0.1 – 2.4 A)
										Ground CT I <sub>n</sub> = 5A (pickup range: 0.5 – 12 A)
										Sensitive ground CT I <sub>n</sub> = 1 A (pickup range: 0.005 – 0.12 A)
										24 – 48 VDC auxiliary voltage (range: 19 – 58 VDC)
										110 – 250 VDC (range: 88 – 300 VDC) and
										110 – 230 VAC (range: 88 – 264 VAC)
										Individual relay
										Mounted in an M+ system†

† If relays are to be mounted in an M+ system, then either an M050 half 19" rack or M100 full 19" rack case must be ordered. The M050 and M100 racks are provided at no additional cost based on the number of relays ordered.

**Accessories**

B1315P1 Depth reducing collar, reduces the mounting depth by 63 mm

