



# MM300

## MOTOR MANAGEMENT SYSTEM

Integrated automation and protection for low voltage motors

### KEY BENEFITS

- Full-featured protection for low voltage AC motors
- Advanced automation capabilities for providing customized protection and integrated process control
- Advanced FlexLogic™ reduces requirement for local PLC's
- Reduced installation space requirements through integration of multiple devices including protection, control functions, pushbuttons, status LEDs and communication interfaces
- Application flexibility with multiple I/O options and programmable logic options (FlexLogic™)
- Enhanced troubleshooting tools including sequence of event records and waveform capture
- Powerful communications including Serial, Ethernet, Profibus, and DeviceNet protocols
- Small form factor and remote display options designed to fit in MCC buckets

### APPLICATIONS

- Low Voltage three phase AC motors
- MCC or stand alone panel mount applications
- Reversing and Reduced Voltage applications
- Motor applications requiring advanced Automation or Control such as conveyor systems or well recovery pumps
- IEC or NEMA class motors

### FEATURES

#### Protection and Control

- Enhanced Thermal Modeling
- Mechanical Jam / Stalled Rotor
- Undercurrent
- Underpower
- Acceleration Time
- Current Unbalance
- Ground Fault
- Sensitive Ground Fault
- Phase Overvoltage / Undervoltage
- Auxiliary Undervoltage
- Phase Reversal
- VT Fuse Failure
- Thermistor
- RTD Overtemperature

#### Automation

- Programmable Flexlogic™ option
- Starter Control
- Process Interlocks
- Programmable inputs and outputs
- Undervoltage Auto-restart

#### Metering & Monitoring

- Metering - current, voltage, power, energy, frequency, RTD, Thermistor
- Oscillography - analog values at 32 samples/cycle and digital states
- Event Recorder - Up to 256 time tagged events with 1ms res.
- Advanced device health diagnostics

#### Communications

- Networking Interfaces - Two Wire RS485, RJ45 Ethernet
- Multiple Protocols (Modbus RTU, Modbus TCP/IP, Internally powered Profibus, ODVA compliant DeviceNet)
- Programming Ports - USB, RS485
- Network Time Protocol (when ordered with Ethernet)

#### User Interface

- Control panel with 12 status LED's, Motor Control and function keys
- Color HMI Display featuring a full color graphical display, Motor and system status LED's, USB programming port and motor control keys.

#### EnerVista™ Software

- State of the art software for configuration and commissioning GE Multilin products
- Graphical Logic Designer and Logic Monitor to simplify designing and testing procedures
- Document and software archiving toolset to ensure reference material and device utilities are up-to-date



Digital Energy  
Multilin

## Protection and Control

The MM300 is a digital motor protection and control system, designed for Low Voltage motor applications. Flexible and powerful, the MM300's protection can be scaled to the specific requirements of your system.

### Motor Thermal Model

To provide optimal protection and maximize run time, the MM300 employs an advanced thermal model, consisting of six key elements:

- Overload Curves
- Unbalance Biasing
- Hot/Cold Safe Stall Ratio
- Motor Cooling Time Constants
- Start Inhibit and Emergency Restart
- RTD Biasing (Optional)

### Overload Curves

The MM300 thermal model can be programmed with one of 15 standard overload curves. When properly selected to match the motor manufacturer's thermal damage curves, the MM300 overload curve and Overload Pickup Level will determine the thermal capacity accumulated within the motor.

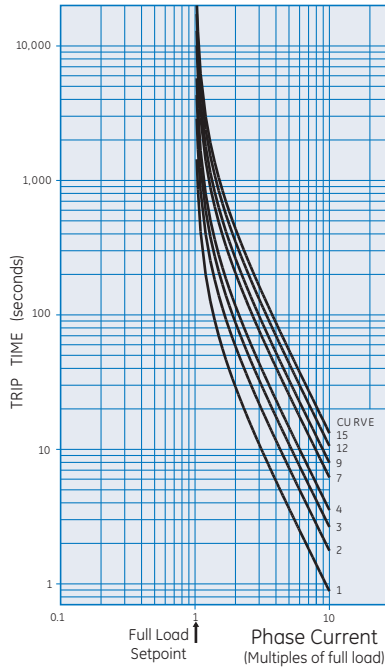

15 Standard Curves available in the MM300

additional rotor heating. A programmable K factor setting allows the amount of derating to be adjusted.

### Hot / Cold Safe Stall Ratio

This ratio defines the steady state level of thermal capacity used (TCU) by the motor. This level corresponds to normal operating temperature of a fully loaded motor and will be adjusted proportionally if the motor load is lower than rated.

### Motor Cool Time Constants

When the MM300 detects that the motor is running at a load lower than the overload pickup setpoint or the motor is stopped, it will start reducing the TCU value exponentially, based on the programmed cool time constants. As cooling occurs at different rates for stopped and running motors, two separate constants are used.

### Unbalance (Negative Sequence) Biasing

Negative sequence current, which causes additional rotor heating, is not accounted for in the thermal limit curves provided by the manufacturer. The MM300 measures current unbalance as a ratio of negative to positive sequence current. The thermal model is then biased to reflect the

### RTD Biasing

The Thermal Model relies solely on measured current to determine motor heating, assuming an ambient temperature of 40°C and normal motor cooling. The actual motor temperature will increase due to abnormally high ambient temperatures or if the motor cooling systems have failed. RTD Biasing enhances the motor thermal model by calculating the thermal capacity used based on available Stator RTD temperatures.

## Functional Block Diagram

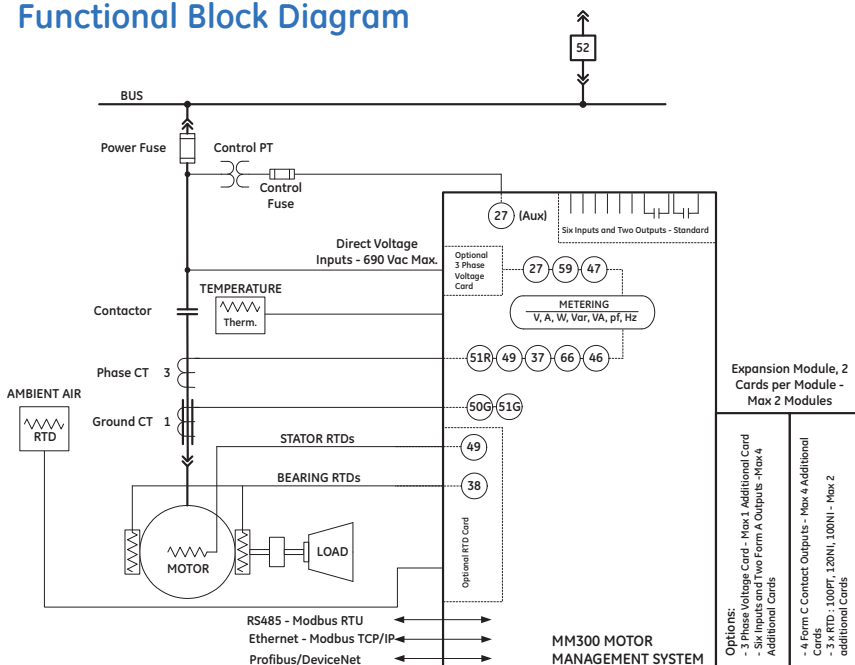

### ANSI Device Numbers & Functions

Device Number	Function
27P	Phase Undervoltage
37	Undercurrent & Underpower
38	Bearing RTD
46	Stator Current Unbalance
49	Stator RTD
50G	Ground/Sensitive Ground Overcurrent
51R	Mechanical Jam
50P	Phase Overvoltage Acceleration Protection Load Increase Alarm Fuse Failure Protection

Expansion Module, 2 Cards per Module - Max 2 Modules

Options:  
 - 3 Phase Voltage Card - Max 1 Additional Card  
 - Six Inputs and Two Form A Outputs - Max 4 Additional Cards  
 - 4 Form C Contact Outputs - Max 4 Additional Cards  
 - 3 RTD - 1.00V, 1.20V, 1.00V - Max 2 Additional Cards

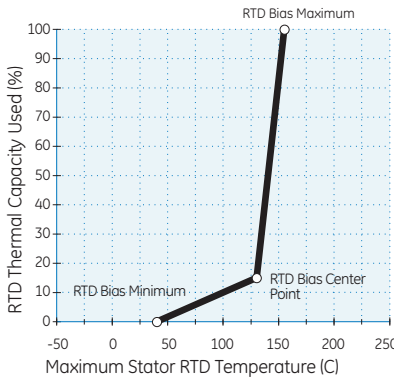

RTD Biasing curve

RTD Biasing does not replace the TCU calculated using the motor current. It provides a second and independent measure of thermal capacity used. Based on a programmable curve, the MM300 will calculate the TCU at any given temperature. This TCU is then compared to that of the thermal model, and the larger of the two will be used.

To protect against faulty stator RTD's, a TCU of 100% based on RTD Biasing will not cause a trip to be issued unless the motor current has exceeded the Overload Pickup Level.

### Motor Start Supervision

Motor Start Supervision consists of the following features: Time-Between-Starts, Start-per-Hour, Restart Time.

These elements guard the motor against excessive starting duty, which is normally defined by motor manufacturer in addition to the thermal damage curves.

### Mechanical Jam and Acceleration Time

These two elements are used to prevent motor damage during abnormal operating conditions such as driven load jams and excessively long acceleration times

### Ground Fault

This function is designed to protect motors against phase to ground faults. The MM300 comes with two separate ground CT inputs intended for one of two different ground protection:

- Core balance (Zero sequence) .
- Residual

### Voltage Protection

The MM300 comes standard with a single phase voltage input, providing single phase underpower, auxiliary undervoltage and optional undervoltage auto-restart functionality.

Optional 3 phase voltage inputs offer the additional following protection elements:

- Undervoltage
- Overvoltage
- Phase Reversal
- Three Phase Underpower
- VT Fuse Failure

### Current Unbalance

In addition to Thermal model biasing, current unbalance is available in the MM300 relay as independent element with a built-in single phasing detection algorithm.

### Thermistor

A single input from a motor winding thermistor is provided with the MM300. The MM300 can accept both positive temperature coefficient (PTC) and negative temperature coefficient (NTC) sensors. A thermistor level can be selected for both alarm and trip.

## Advanced Automation

The MM300's powerful I/O and programmable flexlogic options offer advanced automation control, reducing the need for additional programmable controllers or discrete control relays.

### FlexLogic™

The MM300 optionally includes a control logic engine called FlexLogic™. This provides the ability of creating customized protection and control schemes thereby minimizing the need and the associated costs, of auxiliary components and wiring. Using FlexLogic™, the MM300 can be configured to specify what actions will be taken based on the status of protection or control elements, as well as inputs driven by connected sensors and equipment.

### Scalable Hardware

The MM300 is available with a multitude of I/O configurations to suit most application needs. The expandable modular design allows for easy configuration and future upgrades.

- Up to 30 digital inputs (voltage rating up to 300V) and up to 18 digital outputs are available and can be used to monitor and control a wide range of auxiliary equipment
- Types of digital outputs include trip-rated Form-A and Form-C

## Monitoring and Metering

The MM300 includes high accuracy metering for all AC signals. Voltage, current, power metering, and temperature all available options. Current and voltage parameters are available as total RMS magnitude and angle.

### Fault and Disturbance Recording

The advanced disturbance diagnostic features within the MM300 can significantly reduce the time needed for troubleshooting power system events and reconstruction. Recording functions include:

- Sequence of Event Recorder (SOE) - 256 time stamped events
- Optional enhanced diagnostics with:
  - Waveform capture with up to 10 Analog Channels \*
  - Data Logger with 10 channel RMS recorder

### Advanced Device Health Diagnostics

The MM300 performs comprehensive device health diagnostic tests during startup and continuously at runtime to test its own major functions and critical hardware. These diagnostic tests monitor for conditions that could impact the MM300's performance, evaluate the criticality of this impact and present device status via SCADA communications and front panel display. Providing continuous monitoring and early detection of possible issues helps improve system availability by employing predictive maintenance

## FlexLogic™ Designer

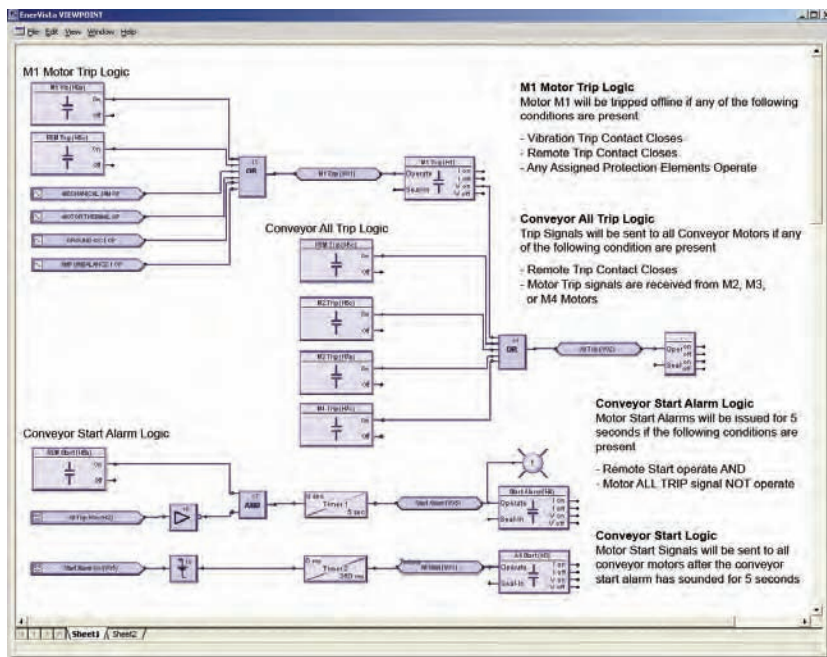

Flexlogic™ and additional I/O options allow the MM300 to replace local programmable controllers in LV applications, like conveyor belts as in this example

Motor Protection

## Communications

The MM300 utilizes the most advanced communications technologies available today making it the easiest and most flexible motor protection relay to use and integrate into new and existing infrastructures. Multiple communication ports and protocols allow control and easy access to information from the MM300. All communication ports are capable of communication simultaneously. The MM300 supports the most popular industry standard protocols enabling easy, direct integration into HMI and electrical SCADA systems. Modbus RTU is provided standard with a RS485 networking port. The following optional protocols and communication ports are available

- Fieldbus Protocol with dedicated port.
  - ODVA Compliant DeviceNet
  - Internally powered Profibus
- Modbus TCP/IP with RJ45 10/100baseT Ethernet port

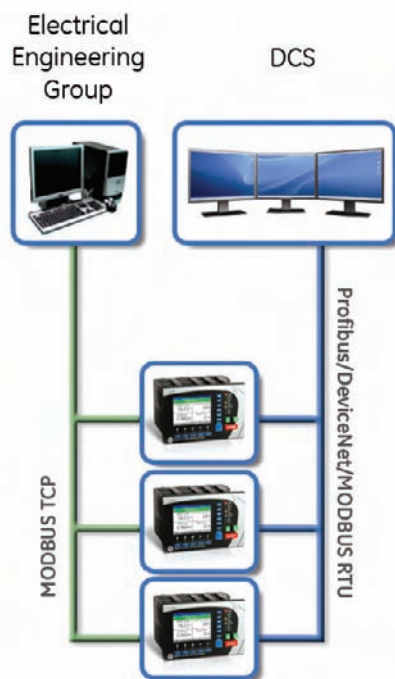

MM300 Dual Architecture Communication

## Profibus DP

Providing a high degree of communication flexibility, the MM300 supports both Profibus DP-V0 and DP-V1. Profibus DP-V0 provides high-speed cyclic data exchange between distributed field devices and the Profibus master. In addition to the high-speed cyclic data communication with DP-V0, DP-V1 provides communication of acyclic data information between the slaves and the engineering workstation, which allows for independent diagnosing and fine-tuning of each slave on the network.

## Rapid Device Replacement

The MM300 supports Rapid Device Replacement, which is compatible with DeviceNet scanners that use Automatic Device Replacement (ADR) functionality. When Rapid Device Replacement is used in DeviceNet networks, this allows rapid change of MM300 devices with minimum process interruption.

When using Rapid Device Replacement, the MM300 can be replaced without the need to manually configure settings. The DeviceNet scanner will automatically recognize a new device and download the key protection, control and communication settings from the original MM300, reducing process downtime and manual setting file configuration.

## EnerVista™ Software

The EnerVista™ Suite is an industry-leading set of software programs that simplifies every aspect of using the MM300 relay. The EnerVista™ suite provides all the tools to monitor the status of the protected asset, maintain the relay, and integrate information measured by the MM300 into DCS or SCADA monitoring systems. Convenient COMTRADE and Sequence of Events viewers are an integral part of the MM300 Setup software included with every MM300 to carry out postmortem event analysis to ensure proper protection system operation.

## EnerVista™ Launchpad

EnerVista™ Launchpad is a powerful software package that provides users with all of the setup and support tools needed for configuring and maintaining GE Multilin products. The setup software within

Launchpad allows configuring devices in real-time by communicating using serial, Ethernet, or modem connections, or offline by creating setting files to be sent to devices at a later time.

Included in Launchpad is a document archiving and management system that ensures critical documentation is up-to-date and available when needed. Documents made available include:

- Manuals
- Application Notes
- Guideform Specifications
- Brochures
- Wiring Diagrams
- FAQs
- Service Bulletins

### Viewpoint Monitoring

Viewpoint Monitoring is a simple-to-use and full-featured monitoring and data recording software package for small systems. Viewpoint Monitoring provides a complete HMI package with the following functionality:

- Plug & Play Device Monitoring
- System Single-Line Monitoring & Control
- Annunciator Alarm Screens
- Trending Reports
- Automatic Event Retrieval
- Automatic Waveform Retrieval

### Viewpoint Engineer

Viewpoint Engineer is a set of powerful tools that will allow the configuration and testing of MM300 relays at a system level in an easy-to-use graphical drag-and-drop environment. Viewpoint Engineer provides the following configuration and commissioning utilities:

- Graphical Logic Designer
- Graphical Logic Monitor

### Viewpoint Maintenance

Viewpoint Maintenance provides tools that will create reports on the operating status of the relay, simplify the steps to download fault and event data, and reduce the work required for cyber-security compliance audits. Tools available in Viewpoint

Maintenance include:

- Settings Security Audit Report
- Device Health Report
- Single Click Fault Data Retrieval

### EnerVista™ Integrator

EnerVista™ Integrator is a toolkit that allows seamless integration of GE Multilin devices into new or existing automation systems. Included in EnerVista™ Integrator is:

- OPC/DDE Server
- GE Multilin Drivers
- Automatic Event Retrieval
- Automatic Waveform Retrieval

### User Interface

The MM300 can be ordered with or without a control panel or display. If local control or monitoring is required, there are two available options:

- 1) Control Panel
- 2) Color HMI Display

## Power System Troubleshooting

The MM300 contains many tools and reports that simplify and reduce the amount of time required for troubleshooting power system events.

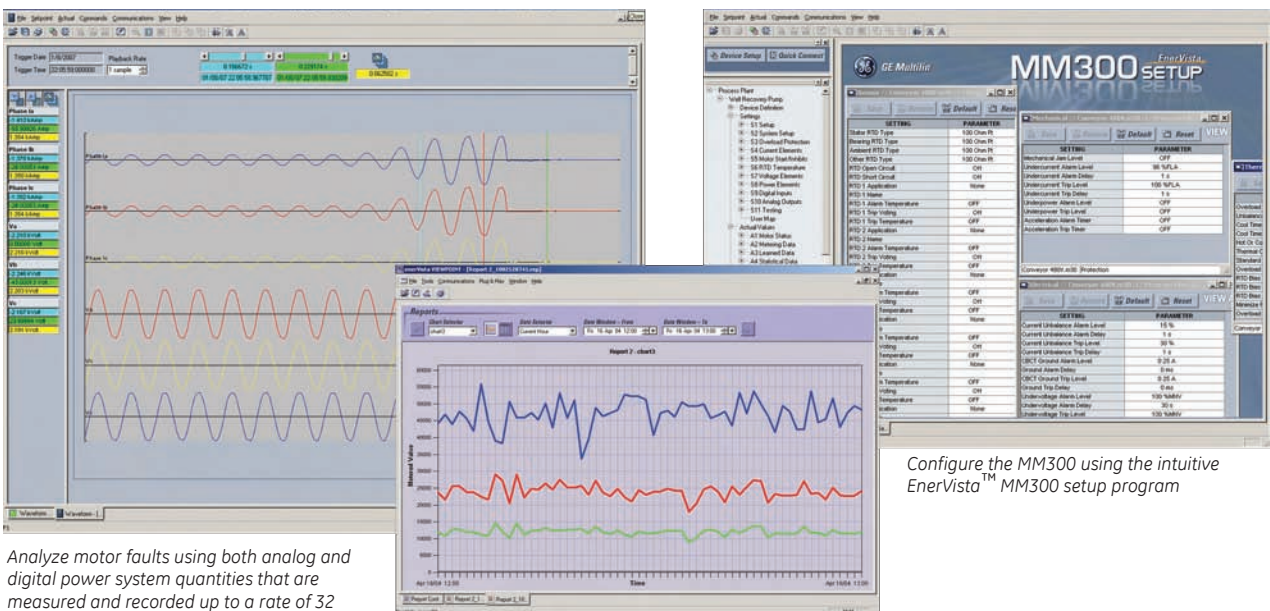

Analyze motor faults using both analog and digital power system quantities that are measured and recorded up to a rate of 32 samples per cycle.

Log motor operating parameters to allow for analyzing motor loading and performance over prolonged periods of time.

Configure the MM300 using the intuitive EnerVista™ MM300 setup program

## Technical Specifications

### PROTECTION

#### ACCELERATION TIMER

Pickup	$I_{av} > I_{cutoff}$
Dropout	$I_{av} < I_{pu}$ or timer expired
Time delay	0.5 to 250.0 seconds in steps of 0.1
Timing accuracy	±500 ms or 1.5% of total time

#### AUXILIARY UNDERVOLTAGE

Pickup level	60 to 90% of NCV
Time delay	1 to 60 seconds in steps of 1
Timing accuracy	± 500 ms

#### CURRENT UNBALANCE

Range	4 to 40% in steps of 1
Accuracy	±2%
Time delay	1 to 60 seconds in steps of 1 s
Timing accuracy	±500 ms

#### FUSE FAILURE (RUNNING STATE ONLY)

#### GROUND FAULT (CBCT OR RESIDUAL)

Pickup level	0.5 to 15.0 A in steps of 0.1 (CBCT); 10 to 100% of FLA in steps of 1% (residual)
Trip time delay on start	0 to 10 s in steps of 0.1 s
Trip time delay on run	0 to 5 s in steps of 0.1 s
Alarm time delay on start/run	0 to 60 s in steps of 1 s
Timing accuracy	±50 ms or ±0.5% of total time

#### LOAD INCREASE

Pickup level	50 to 150% of FLA in steps of 1%
Timing accuracy	±500 ms

#### MECHANICAL JAM

Pickup level	1.01 to 4.50 × FLA in steps of 0.01
Time delay	0.1 to 30.0 seconds in steps of 0.1
Timing accuracy	±500 ms

#### PHASE UNDERVOLTAGE

Pickup level	101 to 120% of rated in steps of 1%
Time delay	1 to 60 seconds in steps of 1 s
Timing accuracy	±500 ms

#### PHASE OVERVOLTAGE

Pickup level	60 to 99% of rated in steps of 1
Time delay	1 to 60 seconds in steps of 1 s
Timing accuracy	±500 ms

#### RTD PROTECTION

RTD types	three-wire (100 ohm Platinum)
Range	-50 to 250°C in steps of 1
Hysteresis	2°C

#### THERMAL MODEL

Standard curve time multiplier	1 to 15 in steps of 1
Thermal overload pickup	1.01 to 1.25 in steps of 0.01
Motor full load current (FLA)	0.5 to 1000 A in steps of 0.1
Motor rated voltage	100 to 690 V AC
Elements	trip and alarm

#### THERMISTOR

Sensor types	PTC (RHOT = 100 to 30 kohms); NTC (RHOT = 100 to 30 kohms)
--------------	--

#### UNDERCURRENT

Pickup level	1 to 100% of FLA in steps of 1
Time delay	1 to 60 seconds in steps of 1

#### UNDERPOWER

Pickup level	1 to 100% of kW in steps of 1
Time delay	1 to 60 seconds in steps of 1

#### VOLTAGE PHASE REVERSAL

Configuration	ABC or Rev starter
---------------	--------------------

### METERING AND MONITORING

#### EVENT RECORDER

Capacity	256 events
Time tag	1 ms
Data storage	non-volatile memory

#### FREQUENCY METERING

Range	40.00 to 70.00 Hz in steps of 0.01
-------	------------------------------------

#### POWER METERING

Real power range	-2000.0 to 2000.0 kW in steps of 0.1
Apparent power range	0.0 to 2500.0 kVA in steps of 0.1

#### POWER FACTOR METERING

Range	-0.99 to +0.99 in steps of 0.01
-------	---------------------------------

### CONTROL

#### UNDERVOLTAGE RESTART

Dropout/Pickup Level	60 to 100% NCV in steps of 1%
Short Dip Time	100 to 500 ms or OFF in steps of 10 ms
Medium Dip Time	0.1 to 10.0 s in steps of 0.1 s
Medium Dip Delay	0.2 to 60 s in steps of 0.2 s
Long Dip Time	0.5 to 60.0 min or OFF in steps of 0.5 min
Long Dip Delay	1.0 to 1200.0 s in steps of 1.0 s
Time Accuracy	±1 s or ±5% of total time

### USER INTERFACE

#### GRAPHICAL CONTROL PANEL

Size	height 102mm, width 153mm, depth 35mm
LCD	3.5-inch colour, 320 by 240 pixels
LED Indicators	10 LEDs
Pushbuttons	Start A, Start B, Stop, plus 11 LCD screen display control keys
Ports	USB 2.0 port for laptop computer connection

#### INPUTS

CONTROL VOLTAGE INPUT (UNDERVOLTAGE RESTART SOURCE)	110 to 690 V AC in steps of 10
External VT primary	(if used)
Input range	60 to 300 V AC
Nominal frequency	50 or 60 Hz
Accuracy	±5% of reading

#### DIGITAL INPUTS

Fixed pickup	65 V AC
Recognition time	2 cycles
Current draw at rated voltage	60 mA @ 120 V; 75 mA @ 240 V
Input impedance	Momentarily sampled every cycle
Type	1.7 kΩ
External switch	opto-isolated inputs
Maximum input voltage	wet contact
	300 V AC

#### GROUND CURRENT INPUT (50:0.025)

CT primary	0.5 to 15.0 A
Nominal frequency	50 or 60 Hz
Accuracy (CBCT)	±0.1 A (0.5 to 3.99 A) ±0.2 A (4.0 A to 15 A)

#### PHASE CURRENT INPUTS (INCLUDING RESIDUAL GROUND CURRENT)

Range	0.2 to 40 A (8 × CT), direct connection up to 5 A FLA combined 1 A / 5 A
Input type	50 or 60 Hz
Frequency	ExtCT: ±2% of reading or ±1% of 8× CT Primary, whichever is greater
Accuracy	Direct: ±2% of reading or ±0.1 A, whichever is greater Withstand (at 5A nominal) 0.2 s at 100× 1.0 s at 50× 2.0 s at 40× continuous at 3× rated current

#### INPUTS (CON'T)

#### PHASE VOLTAGE INPUTS (THREE-PHASE VOLTAGE)

Input range	208 to 690 V
Nominal frequency	50 or 60 Hz
Accuracy	±2% of reading, or ±1 V, whichever is greater

#### RTD INPUTS

Sensor type	Three-wire RTD (100 ohm Platinum)
Sensing current	5 mA
Accuracy	±3°C

#### THERMISTOR INPUTS

Sensor type	Positive temperature coefficient PTC (RHOT = 100 to 30000 ohms), negative temperature coefficient NTC (RHOT = 100 to 30000 ohms)
-------------	--

#### Accuracy

Accuracy	±6% of reading or ±100 ohms, whichever is greater
----------	---

### OUTPUTS

#### OUTPUT RELAYS

Configuration	electromechanical form-A (I/O_C) and form-C (I/O_D)
Contact material	silver-alloy
Operate time	10 ms
Minimum contact load	10 mA at 5 V DC
Maximum switching rate	300 operations per minute (no load), 30 operations per minute (load)
Mechanical life	10 000 000 operations
Continuous current	10 A
Make and carry for 0.2s	30 A per ANSI C37.90

#### OUTPUT RELAY BREAK CAPACITY (FORM-A RELAY)

AC resistive, 120 V AC	10 A
AC resistive, 240 V AC	10 A
AC inductive, PF = 0.4 pilot duty	2 A
DC resistive, 30 V DC	10 A

#### OUTPUT RELAY BREAK CAPACITY (FORM-A RELAY)

AC resistive, 120 V AC	10 A normally-open, 5 A normally-closed
AC resistive, 240 V AC	10 A normally-open, 8 A normally-closed
AC inductive, PF = 0.4 pilot duty	2.5 A
DC resistive, 30 V DC	10 A

### POWER SUPPLY

#### POWER SUPPLY

Nominal	120 to 240 V AC 125 to 250 V DC
Range	60 to 300 V AC (50 and 60 Hz) 84 to 250 V DC

#### ALL RANGES

Power consumption	16 W typical, 25 W maximum
-------------------	----------------------------

### COMMUNICATIONS

#### DEVICENET (COPPER)

Modes	slave (125, 250, and 500 kbps)
-------	--------------------------------

#### ETHERNET (COPPER)

Modes	10/100 MB (auto-detect)
Connector	RJ-45
Protocol	Modbus TCP

#### PROFIBUS (COPPER)

Modes	DP V0 slave, up to 1.5 Mbps
-------	-----------------------------

#### RS485 PORT

Protocol	Modbus RTU
----------	------------

#### USB PORT (GRAPHIC CONTROL PANEL ONLY)

Standard specification	Compliant with both USB 2.0 and USB 1.1
------------------------	---

### TYPE TESTS

Dielectric voltage withstand:	EN60255-5
Impulse voltage withstand:	EN60255-5
Damped Oscillatory Discharge:	IEC61000-4-18 / IEC60255-22-1
Electrostatic Discharge:	EN61000-4-2 / IEC60255-22-2
RF immunity:	EN61000-4-3 / IEC60255-22-3
Fast Transient Disturbance:	EN61000-4-4 / IEC60255-22-4
Surge Immunity:	EN61000-4-5 / IEC60255-22-5
Conducted RF Immunity:	EN61000-4-6 / IEC60255-22-6
Voltage interruption and Ripple DC:	IEC60255-11
Radiated & Conducted Emissions:	CISPR11 / CISPR22 / IEC60255-25
Sinusoidal Vibration:	IEC60255-21-1
Shock & Bump:	IEC60255-21-2
Power magnetic Immunity:	IEC61000-4-8
Pulse Magnetic Immunity:	IEC61000-4-9A
Voltage Dip & interruption:	IEC61000-4-11
Damped Oscillatory:	IEC61000-4-12
Harmonics & Interharmonics:	IEC61000-4-13
Voltage Ripple:	IEC61000-4-17
Ingress Protection:	IEC60529
Environmental (Cold):	IEC60068-2-1
Environmental (Dry heat):	IEC60068-2-2
Relative Humidity:	IEC60068-2-30
Cyclic:	UL508 / UL C22.2-14 / UL1053
Safety:	UL508 / UL C22.2-14 / UL1053

### TESTING AND CERTIFICATION

#### CERTIFICATION

ISO	Manufactured under an ISO9001 registered program
CE	EN60255-5, EN61010-1, EN50263, EN61000-6-2, EN61000-6-4
cULus	UL508, UL1053, C22.2.No 14

### PHYSICAL SPECIFICATIONS

#### DIMENSIONS

Size	Base: 120 mm (W) × 90 mm (H) × 113 mm (D) [+ terminals 10mm] Expansion: 62 mm (W) × 90 mm (H) × 113 mm (D) GCP: 153 mm (W) × 102 mm (H) × 35 mm (D) BCP: 75 mm (W) × 75 mm (H) × 31 mm (D)
Weight (Base)	0.75 kg

### ENVIRONMENTAL

#### OPERATING ENVIRONMENT

Ambient temperature:	Storage / Shipping: -40C to +90C* Operating: -20C to +60C* * based on 1" around base unit up to 95% non-condensing
Humidity	2
Pollution degree	IP20 (base unit), IP54 (control panel)
IP rating	

## User Interface

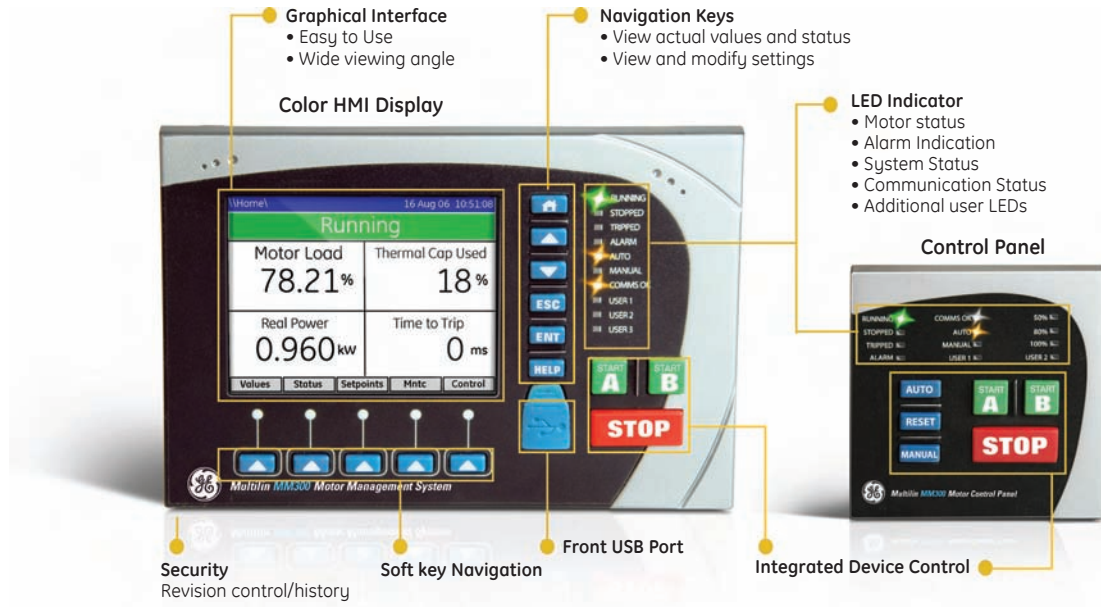

Motor Protection

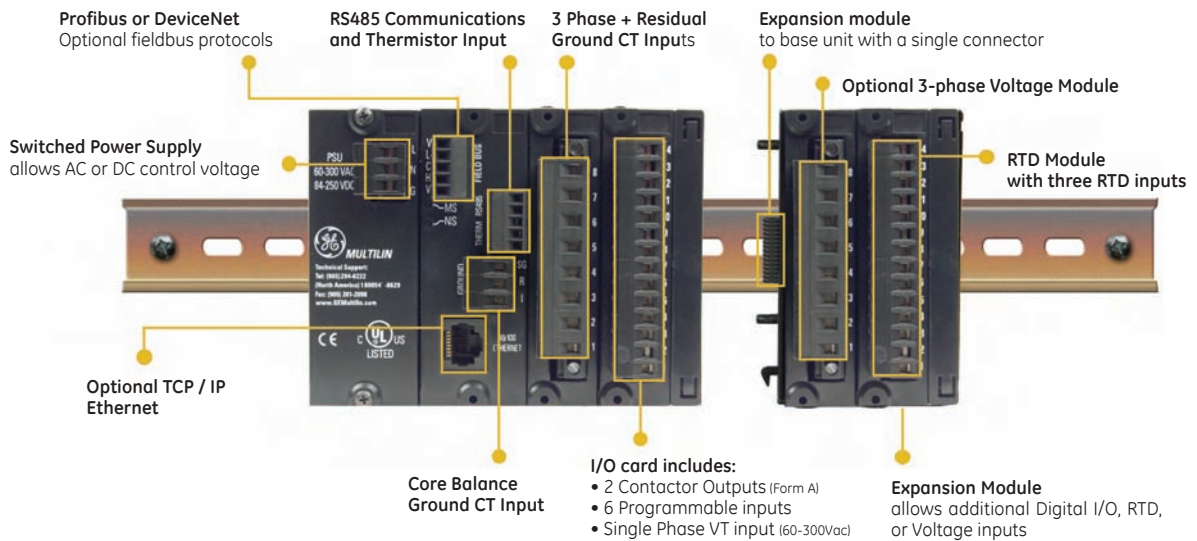

## Dimensions

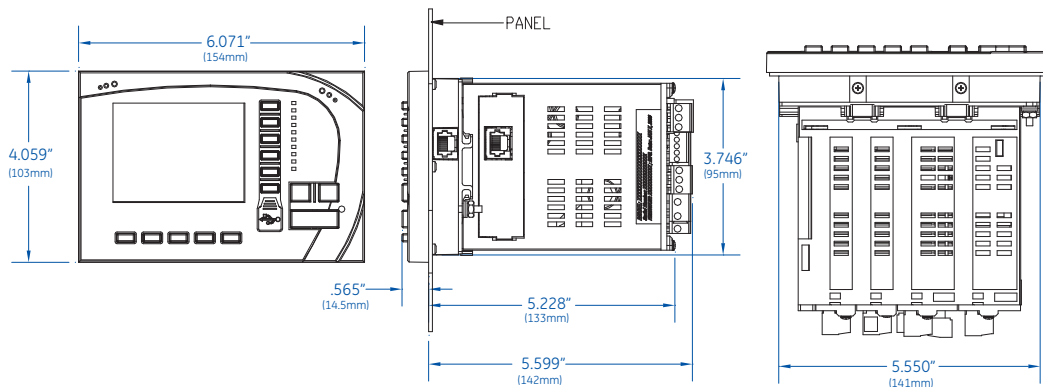

## Mounting

### DIN Rail Mounting

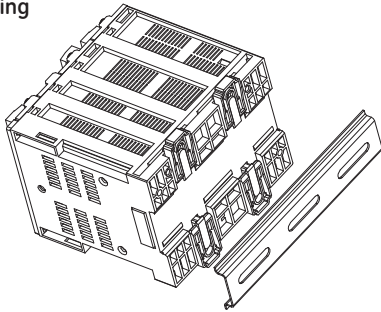

### Door Mounting

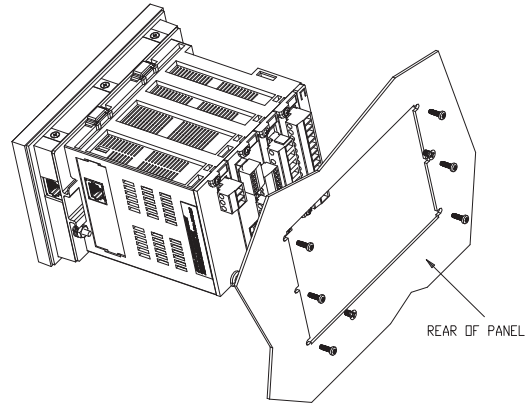

## HandHeld Display (HHD)



The Hand Held Display (HHD) provides a rugged local interface for MM300 Motor Protection Systems where a local display is not used in the MCC.

The HHD provides a graphical color local interface to the MM300 Motor Protection Systems allowing local operators to view and change setting files and quickly access relay diagnostic information.

The HHD provides a clear and detailed view of all motor settings, diagnostic information and metering data available in the MM300 allowing local operators to make informed decisions on the motors operation.

## Ordering

MM300	*	*	*	*	*	*	Base I/O	Expansion Module 1	Expansion Module 2	Description
Control Panel	X									None
	B									Basic Control Panel, no USB
	G									Graphical Control Panel inc USB
Language		E								English (Standard)
		C								Chinese *
Power Supply			H							High (60-300 vac/80-250vdc) (Standard)
Communication				S						RS485 Modbus RTU (Standard)
				D						RS485 + DeviceNet Slave + 10/100 Modbus TCP
				P						RS485 + Profibus DP Slave + 10/100 Modbus TCP
Options					S					Standard Control and Event Recorder
					1					+ Undervoltage Auto-restart
					2					+ Waveform Capture, Data Logger
					3					+ FlexLogic
I/O Modules							A	X	X	None
								B		3 Phase Current + Thermal O/L, Under Current, Single Phase Under Power
								G	G	3 Phase Voltage Metering + 3 Phase Under Power, Under / Over Voltage, Phase reversal
								C	C	3 x RTD : 100PT, 120NI, 100NI - max 2
								C	C	2 x 10A Relay Form A and 6 x Digital Input 60-300ac/ (Standard) - max 5
								D	D	4 x 10A Relay Form C - max 4

### Accessories for the MM300

- |                                 |           |                               |           |
|---------------------------------|-----------|-------------------------------|-----------|
| • MM300 Basic Control Panel     | 18M9-0004 | • MM300 3ft. RS232-RJ45 Cable | 0804-0181 |
| • MM300 Graphical Control Panel | 18M9-0002 | • MM300 3ft. Connector Cable  | 0804-0169 |
| • HandHeld Display (HHD)        | 18M9-0037 | • MM300 6ft. Connector Cable  | 0804-0172 |
| • MM300 3ft. USB Cable          | 0804-0171 | • USB-to-Serial Cable         | 0100-0001 |
| • MM300 1ft. RS232-RJ45 Cable   | 0804-0180 |                               |           |

### Software for the MM300

- |                         |       |
|-------------------------|-------|
| • Viewpoint Engineer    | VPE-1 |
| • Viewpoint Maintenance | VPM-1 |
| • Viewpoint Monitoring  | VP-1  |

### Visit [www.GEMultilin.com/MM300](http://www.GEMultilin.com/MM300) to:



- View Guideform specifications
- Download the instruction manual
- Review applications Notes and support documents
- Buy a MM300 online
- View the MM300 brochure