

# eBoost™

## Guaranteed Higher UPS Efficiency

*Energy consumption is a critical issue for IT organizations as their data center energy demands continue to grow. Their goal is to reduce cost and keep the datacenter running.*

*IT organizations can reduce energy consumption and costs—without sacrificing reliability—with GE's **eBoost** technology.*

### Technology breakthroughs

- Up to 99% UPS efficiency
- Compliant to ITI (CBEMA) curve during undervoltage events
- Up to 3 MVA UPS capacity using Redundant Parallel Architecture (RPA)
- Magnetizing the output transformer ensures a < 2ms transfer time
- Static bypass inductor for filtering utility power
- Battery trickle charge in **eBoost** operating mode

### What is eBoost?

- e = high efficiency (up to 99%)
- Boost = fast power transfer (<2ms)



imagination at work

# eBoost

## Customer benefits

- 80% reduction in UPS losses
- System energy cost savings
- Reduced heat (BTU) generation
- Energy savings from reduced cooling
- Extended UPS component life
- User-programmable scheduling
- Reduced acoustical noise

## double conversion

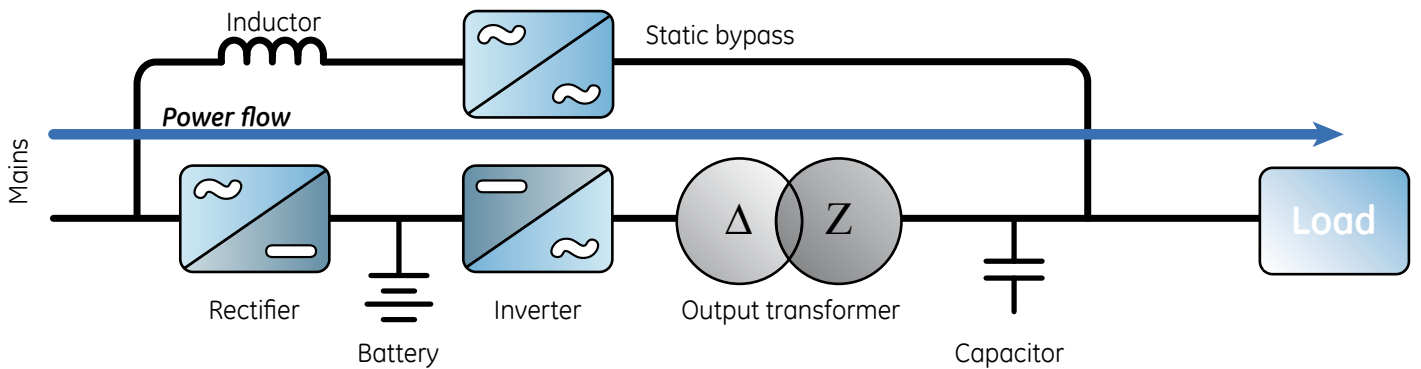

During traditional operation the UPS runs in double conversion mode. Both the rectifier and the inverter are continuously operating, resulting in an efficiency of 92-94%.

## eBoost single module

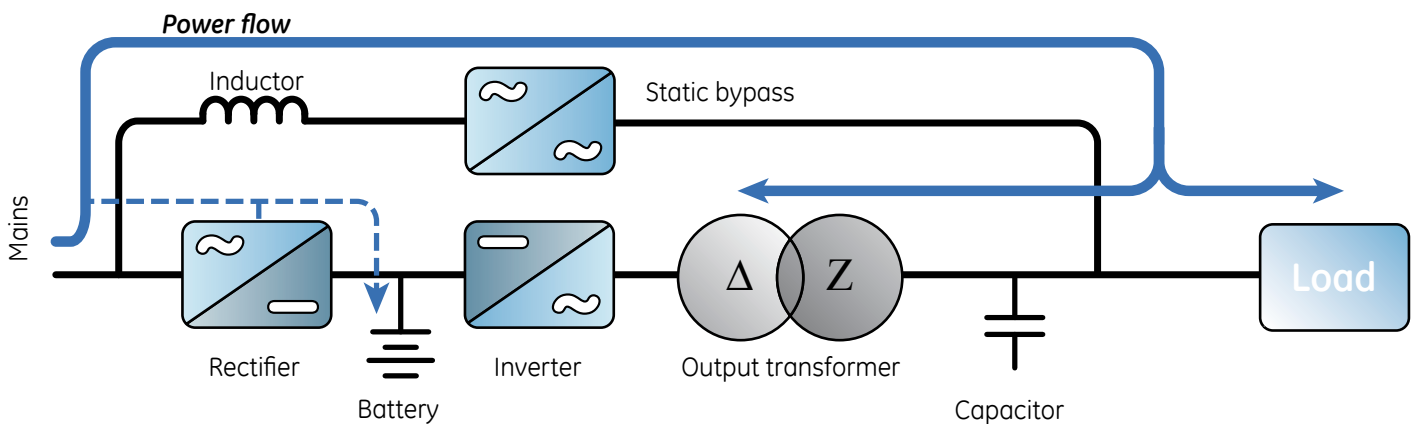

During **eBoost** operation the load is supplied directly by the mains, via the static bypass circuit. This provides an efficiency up to 99%. In case the mains voltage is out of tolerance, the UPS will immediately transfer the load to the inverter in < 2ms. The < 2ms is achieved by our patented\* technology to magnetize the output transformer. The output transformer provides galvanic isolation between inverter and load. The static bypass inductor filters the input AC power during **eBoost** operational mode.

# eBoost in Redundant Parallel Architecture (RPA)

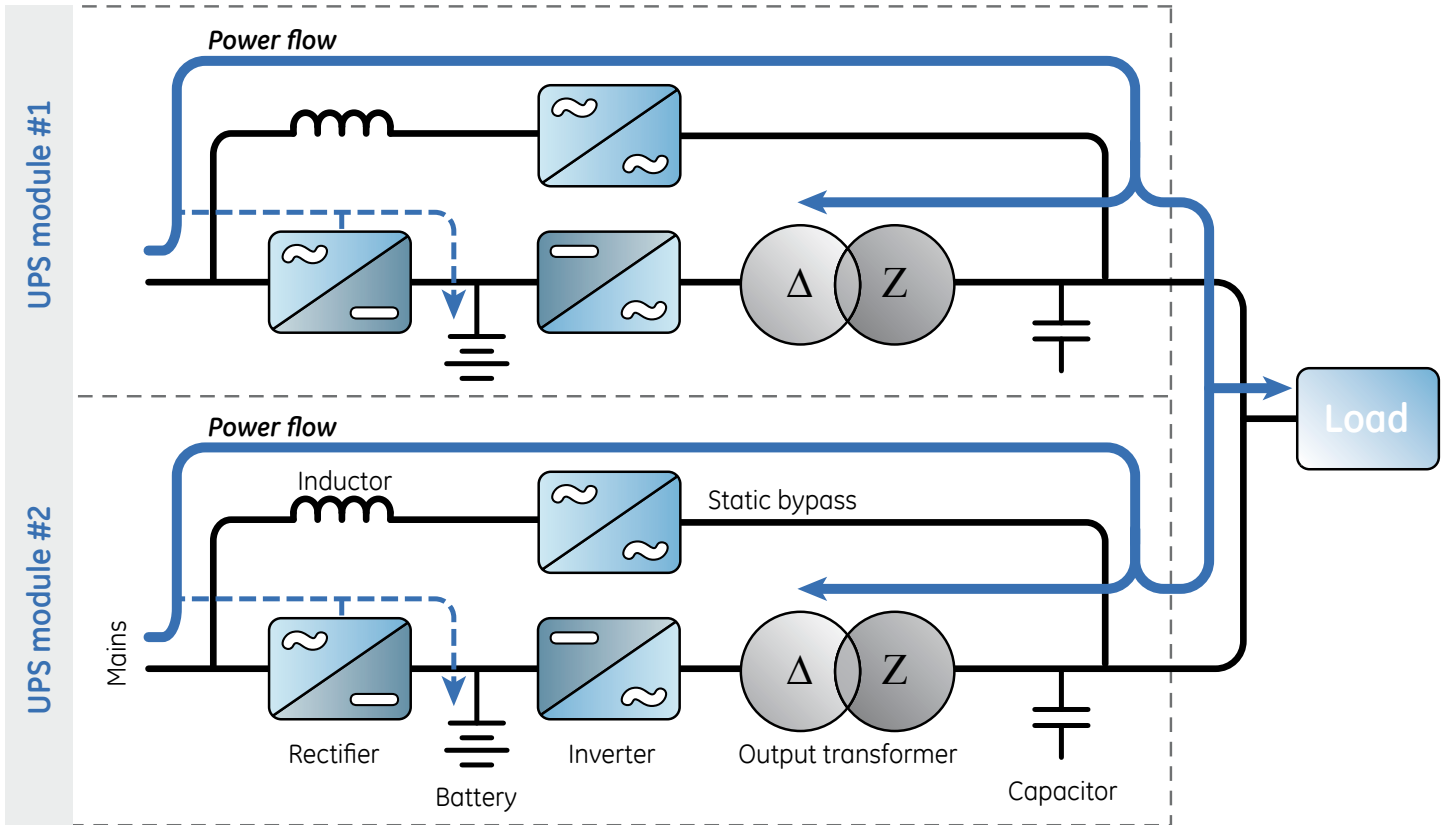

**eBoost** in RPA uses high speed communication and fast digital signal processors (DSP) to parallel up to 6 UPS modules. **eBoost** in RPA provides up to 3 MVA capacity and up to 99% efficiency while maintaining < 2ms transfer time, compliant to the ITI (CBEMA) curve.

## eBoost performance

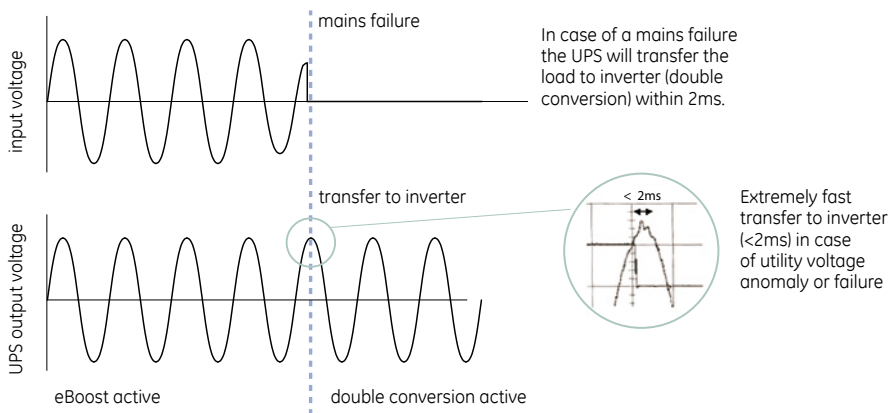

## Specifications

On SG Series UPS products 160-500kVA single module and Redundant Parallel Architecture (RPA) operation:

|                       |             |
|-----------------------|-------------|
| Transfer time         | : < 2ms     |
| Input voltage range   | : ± 10%     |
| Input frequency range | : ± 2%      |
| Efficiency            | : up to 99% |

## eBoost efficiency

**eBoost** provides operating efficiencies up to 99% and is 6% more efficient, on average, across the load range than traditional double conversion UPS operating at less than 92%.

## UPS efficiency comparison

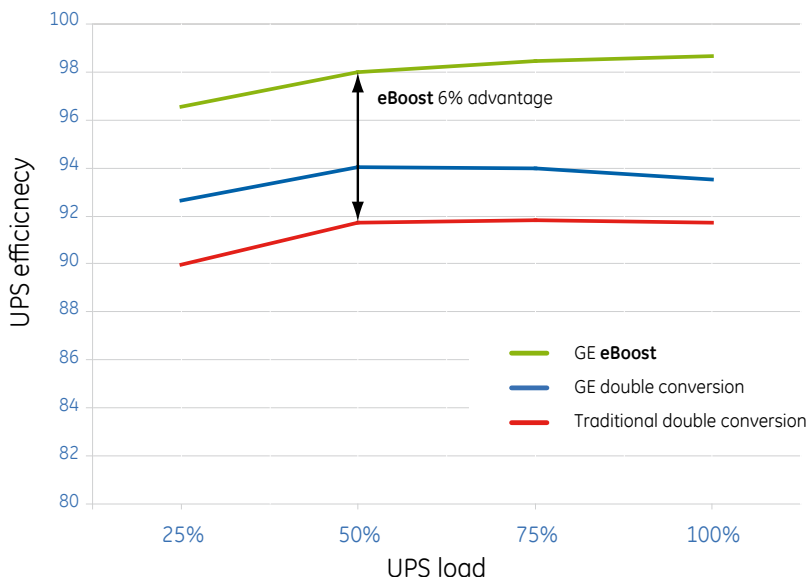

## eBoost savings

**eBoost** operation provides considerable energy life cycle cost savings ranging from €0.5MM to €7MM.\* Savings are dependent upon load, power costs and life cycle duration (years).

\* Assumptions:

- Power cost - €0.10/kw-hr
- Operating hrs/year - 8,760
- Configuration = S+S operating at 50% capacity

## Data center life cycle cost (10 years)

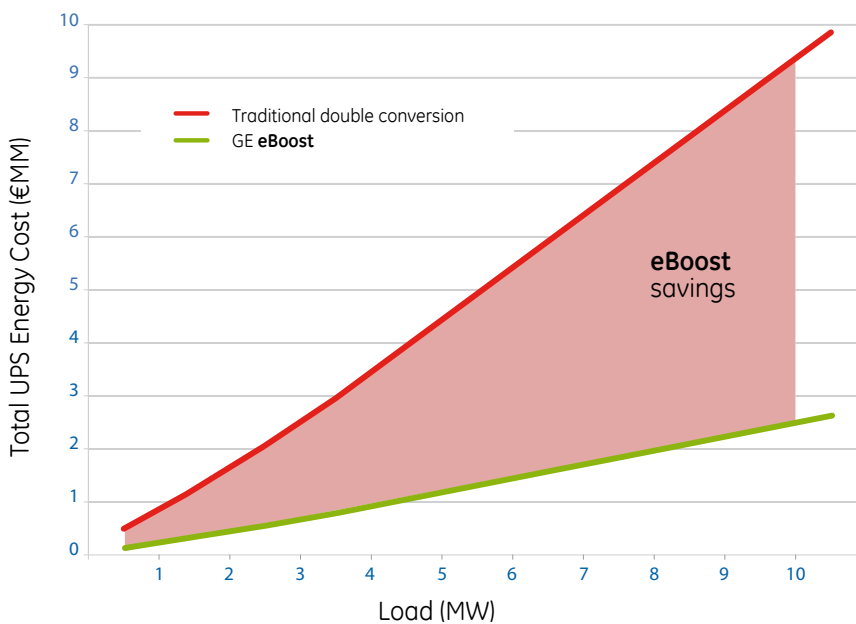

imagination at work

your distributor:

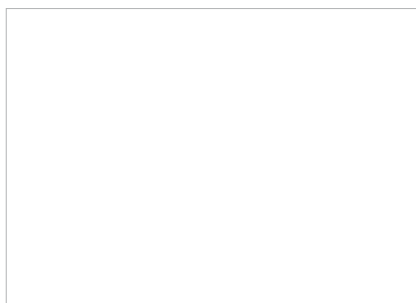

GE Consumer & Industrial SA  
 Via Cantonale 50  
 6595 Riazzino (Locarno)  
 Switzerland  
 T +41 (0) 91 850 51 51  
 F +41 (0) 91 850 52 52  
 E gedeinfo@ge.com

Visit us online at:  
[www.gepowerquality.com](http://www.gepowerquality.com)