



REGULATORY AGENCY APPROVALS



E93779



LR89403

Manufactured to meet the requirements of ANSI/IEEE C57.13.
Classified by U.L. in accordance with IEC 44-1



APPLICATION:

For energy management systems and instrumentation equipment having a high input impedance, eg. 14K ohms minimum.

FREQUENCY:

50-400 Hz.

INSULATION LEVEL:

0.6 kV, BIL 10 kV full wave.

**CONTINUOUS THERMAL
CURRENT RATING FACTOR:**

Models 613-101 thru 613-401:
1.33 at 30°C. amb. 1.0 at 55°C. amb.

Model 613-1000T:

330A at 30°C. amb. 250A at 55°C. amb.

Flexible leads are UL 1015, 105°C, CSA approved,
#16 AWG, 24" long unless otherwise specified.

Approximate weight 1 lb.

5

CATALOG NUMBER	CURRENT RATIO	BURDEN VA	ACCURACY AT 60 HZ
613-101	100:5	1	5 %
613-1250	125:5	1.25	5 %
613-151	150:5	1.5	5 %
613-1750	175:5	1.75	5 %
613-201	200:5	2.5	4 %
613-251	250:5	2.5	4 %
613-301	300:5	3	2 %
613-401	400:5	3	2 %
* 613-1000T	100:0.1	SEE GRAPH	± 3 %

*The Model 613-1000T is intended for use with high input impedance devices that require signal voltages up to 5 VAC. The output can be rectified and filtered for devices requiring DC in, the non-linearity and voltage drop of the rectifiers and filters must be considered in the choice of the loading impedance.

Model 613 Split Core/Clamp On

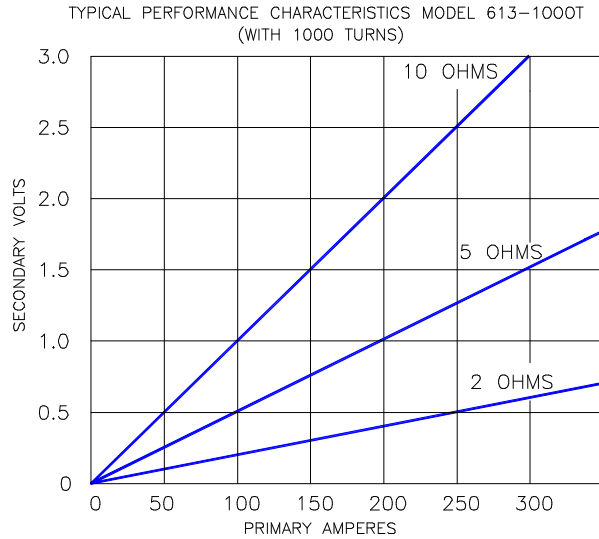

- This transformer is designed for assembly to an existing electrical installation without the need for dismantling the primary bus or cables.

5

Caution:

Proper safety precautions must be followed during installation by a trained electrician. Never install while bus is energized.

The current transformer must have its secondary terminals short circuited or the burden connected, before energizing the primary circuit.

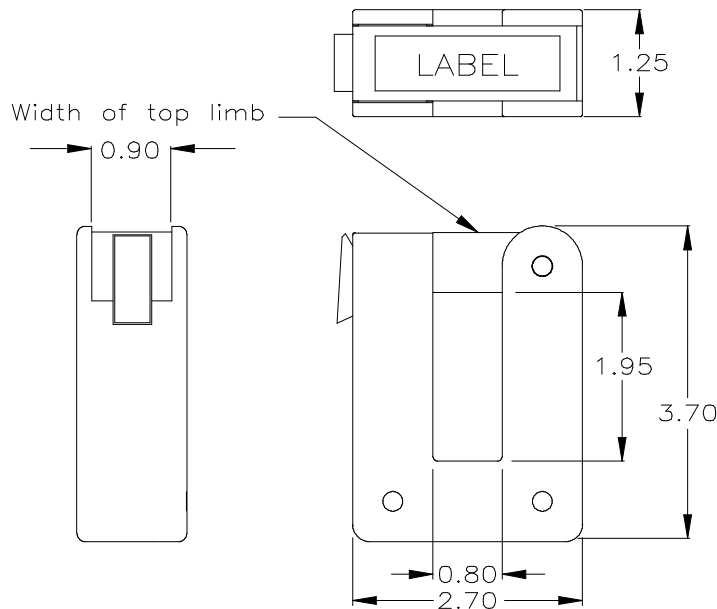

USA, Canada, Asia, Latin America

Tel: +1-800-547-8629

Fax: +1-905-201-2455

e-mail: sales.multilin@ge.com

Europe, Middle East, Africa

Tel: +34-94-485-88-00

Fax: +34-94-485-88-45

e-mail: gemultilin.euro@ge.com

Please refer to our website www.GEMultilin.com for more detailed contact information

CS00A40581 Rev.