



AC Current Transducer Model PCM 0-300 Amps ac to produce 4-20 mA dc

OPERATING RANGE:

Input 0-5 thru 300 Amps ac.
Output: 4-20 mA dc.

FREQUENCY: 50/60Hz.

AMBIENT TEMPERATURE RANGE:

Effect on accuracy $\pm 0.04\%/^{\circ}\text{C}$
Operating: -30°C to $+60^{\circ}\text{C}$
Storage: -55°C to $+85^{\circ}\text{C}$

INSULATION LEVEL:

600 Volts, 10 kV BIL full wave.

CONTINUOUS THERMAL CURRENT RATING FACTOR:

1.33 at 30°C ambient.*
* 6.00 times rated current for 30 seconds.

ACCURACY:

$\pm 0.05\%$ F.S. maximum.
1% maximum to peak ripple on dc out put.
peak ripple on output.

- Output load (R_L): 0-600 ohms.
 - Maximum output: 30 mA dc.
 - Supply Voltage Range: 24V dc $\pm 10\%$.
 - Response Time: $<200\text{ms}$ (10%-90%)
 - Repeatability: $<0.1\%$
 - PCM 5- 200 terminal are brass screws No. 10-32 with one flatwasher, lockwasher and regular nut.
 - PCM 300 terminal are brass studs No. 8-32 with one flatwasher, lockwasher and nut.
- Approximate weight 1.5 lbs.

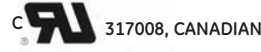

PCM 5 - 200



PCM 300

MODEL NUMBER	INPUT CURRENT RANGE
PCM 5	0 - 5
PCM 10	0 - 10
PCM 20	0 - 20
PCM 30	0 - 30
PCM 50	0 - 50
PCM 75	0 - 75
PCM 100	0 - 100
PCM 150	0 - 150
PCM 200	0 - 200
PCM 300	0 - 300

- The **PCM** transducer accurately converts a sinusoidal ac input to a proportional dc current. The high performance integrated circuit amplifiers achieve a constant current output, insensitive to a variable impedance load. This allows the **PCM** to be easily applied to remote instrumentation, motor control, and energy management installations. The input circuit is average responding.

The output require 24V dc to be applied between the (+) terminal and ground. The output load may be inserted in either the (-) line for a negative ground system. Power supply polarity is critical for correct operation, but an accidental reverse polarity connection will not damage the output. Several transducers can be operated from a single power supply with the only limitation being the maximum current available from the supply itself.

(Example: a one Amp supply will support 50 transducers operating at 20mA dc output.) The maximum output is limited to 30mA dc to prevent damage to external components.

CAUTION:

Some consideration should be given to the ripple content of the external power supply. Any ripple introduced by the power supply will appear at the load resistor.

TYPICAL CHARACTERISTICS

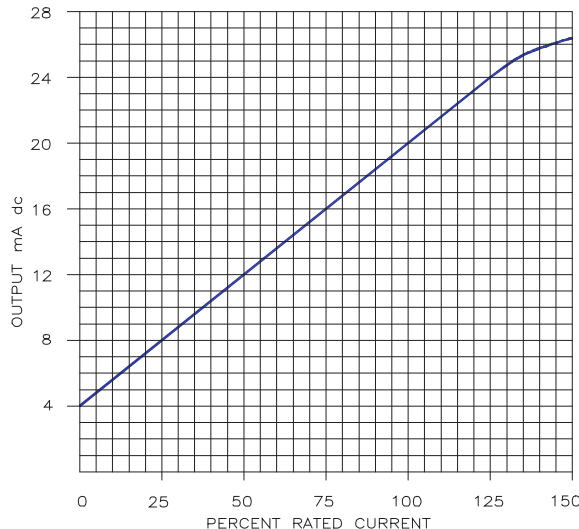

AC Current Transducer

Model PCM 0-300Amps ac to produce 4-20mA dc

Applications Notes

Application #1 Monitoring Loads 300 Amps or Less

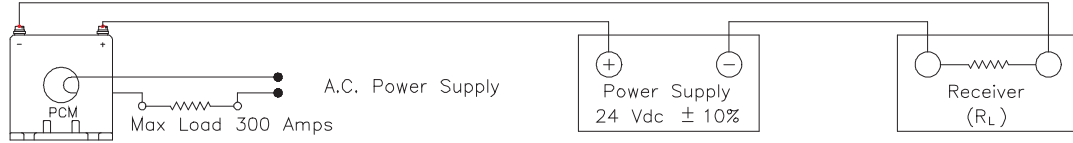

Application #2 Monitoring Loads from a Current Transformer Secondary

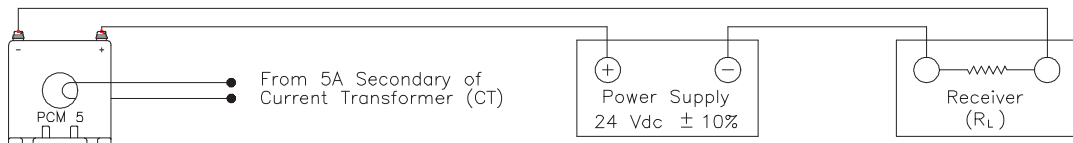

Example

$$\text{When used with a 2000:5 CT } I_{in} = 2000 \times \left(\frac{I_o - 4}{16} \right)$$

$$\text{If } I_o = 10\text{mA then } I_{in} = 2000 \times \left(\frac{10 - 4}{16} \right) = 750 \text{ amps}$$

Application #3 Energizing multiple transducers from a single power supply

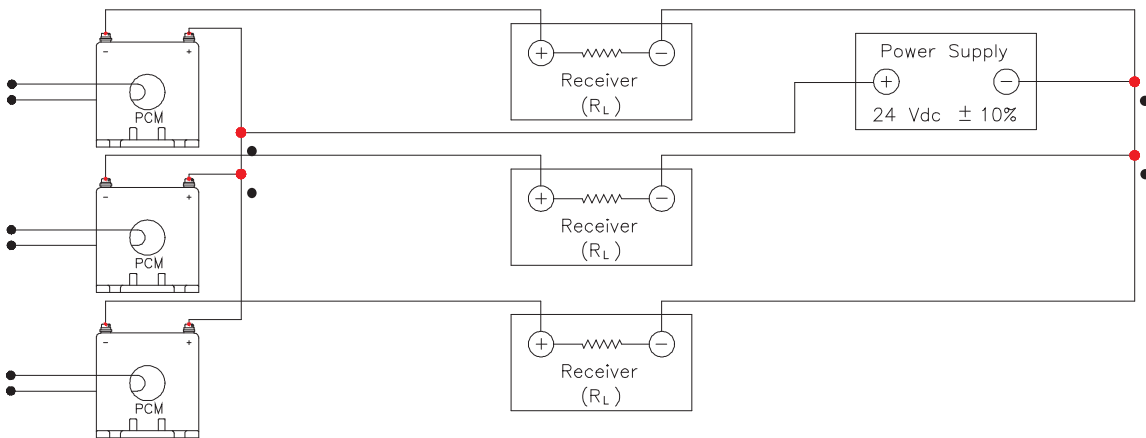

Application

- Calculating $I_{in} = \text{ac Amps measured}$
 $I_o = \text{mA dc out of PCL}$
 Rated Input CT Primary Rating (when monitoring a CT)
 Rated Input PCL Primary Rating (when monitoring direct)
 Where: $I_{in} = \text{Rated input} \times \left(\frac{I_o - 4}{16} \right)$

NOTE: Output current of each PCM is limited to 30mA max. From this the required by using capacity of the D.C. supply can be calculated by multiplying the total number of PCM's times 0.03A to find the maximum requirement output capacity of the supply.

It is possible to achieve an output close to full scale increase output resolution by using multiple turns through the window of the PCM. The following equation would apply:

$$I_{in} = \frac{\text{Rated input Amps}}{\text{No. of Turns}} \times \left(\frac{I_o - 4}{16} \right)$$

EXAMPLE: A PCM 5 is used with two turns and is monitoring a 2A load.

$$\text{If } I_o = 16.8 \text{ mA then } I_{in} = \frac{5}{2} \times \left(\frac{16.8 - 4}{16} \right) = 2 \text{ Amps}$$

AC Current Transducer

Model PCM 0-300Amps ac to produce 4-20mA dc



Do not apply around or remove from Hazardous LIVE conductors.

Cleaning:

Remove dust with a damp cloth. Do not spray with any chemicals.

Caution:

Proper safety precautions must be followed during installation by a trained electrician. Never install or remove while bus is energized. Protective equipment must be used if hazardous parts in the installation where measurement is to be carried out could be accessible.

Dimensions:

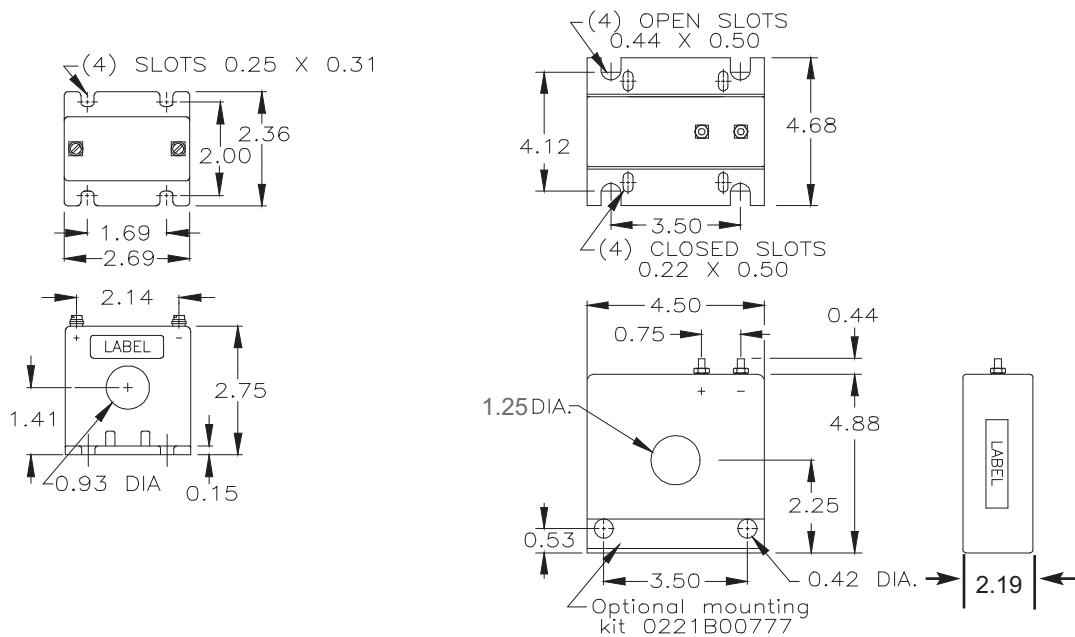

USA, Canada, Asia, Latin America

Tel: +1-800-547-8629

Fax: +1-905-201-2455

e-mail: sales.multilin@ge.com

Europe, Middle East, Africa

Tel: +34-94-485-88-00

Fax: +34-94-485-88-45

e-mail: gmultilin.euro@ge.com